

**Onan**

**RV GenSet**

**Installation Manual**

**KY**

**MicroLite™ 4000 Series**

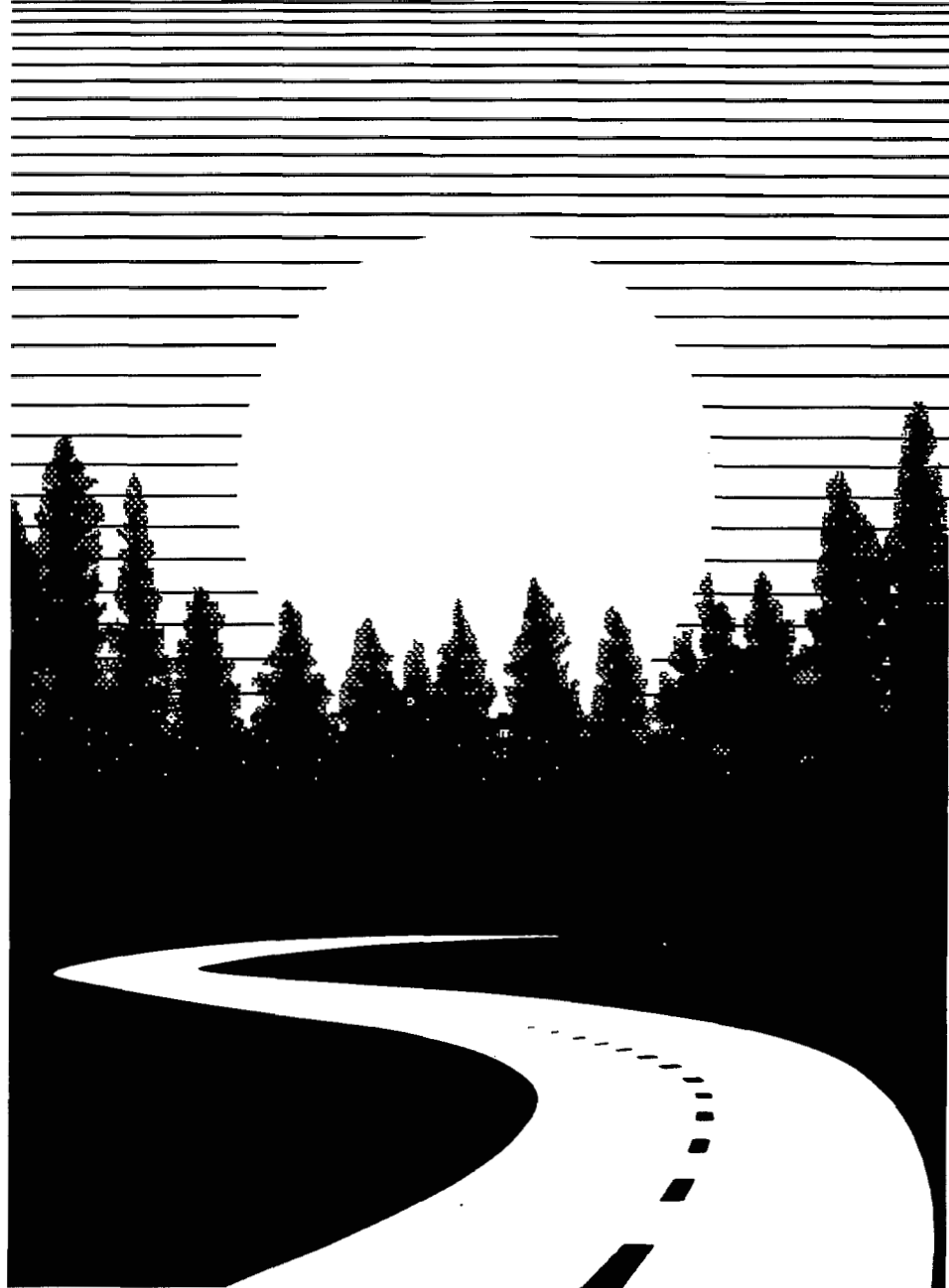



# Table of Contents

---

SECTION	TITLE	PAGE
	<b>SAFETY PRECAUTIONS</b> .....	ii, iii
<b>1</b>	<b>INTRODUCTION</b> .....	1-1
	General .....	1-1
	Installation Codes and Safety Recommendations .....	1-1
	Component Locations .....	1-2
<b>2</b>	<b>SPECIFICATIONS</b> .....	2-1
<b>3</b>	<b>STEP-BY-STEP INSTALLATION OUTLINE</b> .....	3-1
	Introduction .....	3-1
	Preparation .....	3-1
	Compartment Mounting .....	3-2
	Under-Floor Mounting .....	3-3
	Connecting to Vehicle Systems .....	3-5
	Exhaust System .....	3-6
<b>4</b>	<b>MOUNTING</b> .....	4-1
	General .....	4-1
	Compartment Mount .....	4-1
	Under-Floor Mount .....	4-4
<b>5</b>	<b>VENTILATION AND ACOUSTICS</b> .....	5-1
	Ventilation .....	5-1
	Acoustics .....	5-2
<b>6</b>	<b>EXHAUST SYSTEM</b> .....	6-1
	General .....	6-1
	Muffler Recommendations .....	6-1
	Exhaust Installation Guidelines .....	6-1
	Tailpipe Recommendations .....	6-1
<b>7</b>	<b>FUEL SYSTEM</b> .....	7-1
	General .....	7-1
	Gasoline Fuel System .....	7-1
	LPG Fuel System .....	7-3
<b>8</b>	<b>ELECTRICAL CONNECTIONS</b> .....	8-1
	General .....	8-1
	AC Wiring .....	8-1
	DC Wiring .....	8-5
<b>9</b>	<b>INITIAL START AND CHECKS</b> .....	9-1
	Pre-Start Checks .....	9-1
	Initial Starting and Checks .....	9-2
	Installation Review .....	9-4
<b>10</b>	<b>WIRING SCHEMATIC/DIAGRAMS</b> .....	10-1

# Safety Precautions

---

Before operating the generator set, read the Operator's Manual and become familiar with it and the equipment. **Safe and efficient operation can be achieved only if the unit is properly operated and maintained.** Many accidents are caused by failure to follow fundamental rules and precautions.

The following symbols, found throughout this manual, alert you to potentially dangerous conditions to the operator, service personnel, or the equipment.

**⚠ DANGER** *This symbol warns of immediate hazards which will result in severe personal injury or death.*

**⚠ WARNING** *This symbol refers to a hazard or unsafe practice which can result in severe personal injury or death.*

**⚠ CAUTION** *This symbol refers to a hazard or unsafe practice which can result in personal injury or product or property damage.*

## FUEL AND FUMES ARE FLAMMABLE

Fire, explosion, and personal injury can result from improper practices.

- Do not smoke or allow an open flame or spark-producing equipment near the generator set or fuel tank.
- Fuel lines must be adequately secured and free of leaks. Fuel connection at the engine should be made with an approved flexible, non-conductive line.

**GASOLINE AND LPG FUEL MAY BE ACCIDENTALLY IGNITED BY ELECTRICAL SPARKS**, presenting the hazard of fire or explosion that can result in severe personal injury or death. When installing the generator set:

- Keep electrical and fuel lines as far apart as possible. Do not allow contact unless both lines are sheathed.

## EXHAUST GASES ARE DEADLY

- Never sleep in the vehicle with the generator set running unless the vehicle is equipped with an operating carbon monoxide detector.
- Provide an adequate exhaust system to properly expel discharged gases. Do not use engine cooling air to heat a compartment.
- Be sure the unit is well ventilated.

## MOVING PARTS CAN CAUSE SEVERE PERSONAL INJURY OR DEATH

- Before starting work on the generator set, disconnect batteries. This will prevent accidental starting and electrical arcs. Disconnect the Negative (-) battery cable first to reduce the risk of arcing.
- Keep your hands away from moving parts.
- Make sure that fasteners on the generator set are secure. Tighten supports and clamps, keep guards in position over fans, drive belts, etc.
- Do not wear loose clothing or jewelry while working on generator sets. Loose clothing and jewelry can become caught in moving parts. Jewelry can short out electrical contacts and cause shock or burning.
- If adjustment must be made while the unit is running, use extreme caution around hot manifolds, moving parts, etc.

---

## **ELECTRICAL SHOCK CAN CAUSE SEVERE PERSONAL INJURY OR DEATH**

- Disconnect the negative (–) cable at the starting battery before removing protective shields or touching electrical equipment. Use rubber insulative mats placed on dry wood platforms on the ground or over floors that are metal or concrete when around electrical equipment. Do not wear damp clothing (particularly wet shoes) or allow skin surfaces to be damp when handling electrical equipment.
- Use extreme caution when working on electrical components. High voltages can cause injury or death.
- Follow all state and local electrical codes. Have all electrical installations performed by a qualified electrician. Tag open switches to avoid accidental closure.
- **DO NOT CONNECT GENERATOR SET DIRECTLY TO ANY BUILDING ELECTRICAL SYSTEM.** Hazardous voltages can flow from the generator set into the utility line. This creates a potential for electrocution or property damage. Connect only through an approved device and after building main switch is open. Consult an electrician in regard to emergency power use.

## **GENERAL SAFETY PRECAUTIONS**

- Wear safety glasses and protective clothing when servicing batteries. **DO NOT SMOKE** while servicing batteries. Lead-acid batteries emit a highly explosive hydrogen gas that can be ignited by electrical arcing or by smoking.
- Have a fire extinguisher rated ABC nearby. Maintain extinguisher properly and become familiar with its use.
- Benzene and lead, found in some gasoline, have been identified by some state and federal agencies as causing cancer or reproductive toxicity. When checking, draining or adding gasoline, take care not to ingest, breathe the fumes, or contact gasoline.
- Used engine oils have been identified by some state or federal agencies as causing cancer or reproductive toxicity. When checking or changing engine oil, take care not to ingest, breathe the fumes, or contact used oil.
- Do not work on this equipment when mentally or physically fatigued, or after consuming any alcohol or drug that makes the operation of equipment unsafe.

RG-1N1



# 1. Introduction

---

## GENERAL

This manual provides installation guidelines for the MicroLite™ (KY) generator set. The generator set must be installed properly to operate reliably, quietly, and safely. Read this entire manual before starting the installation.

For operation and maintenance procedures, see the Operator's Manual (981-0132) that accompanies each genset.

When properly installed, this generator set meets or exceeds the following requirements:

- National Electrical Code, NFPA 70-Article 551
- ANSI/RVIA EGS-1 - 1986, Generator Set Standard
- ANSI A119.2/NFPA 501C Standard for Recreational Vehicles
- NFPA Liquefied Petroleum Gas
- CSA Electrical bulletin 946

The RV manufacturer and/or the set installer must comply with local codes such as California administrative Code title 25, which applies to generator set installation. The RV installer bears sole responsibility for the selection of the appropriate generator set, installation design, and installation.

Consider the following requirements before installing the set. Each topic is covered in the following text.

- Level and supportive mounting surface
- Adequate cooling air
- Adequate fresh induction air
- Discharge of circulated air
- Noise levels
- Accessibility for maintenance and service
- Exhaust connections
- Fuel supply
- Electrical connections

MicroLite is a trademark of the Onan Corporation

## INSTALLATION CODES AND SAFETY RECOMMENDATIONS

The following list of Installation Codes and Safety Recommendations applies to the installation and operation of RV generator sets. The address of each agency is listed so that copies of the codes may be obtained for reference. Installation codes and recommendations are subject to change, and may vary by location or over time. The RV manufacturer and the genset installer bear sole responsibility for following all applicable codes and regulations.

1. ANSI-A119.2  
FMVSS 301      Recreational Vehicle  
Industry Association  
14650 Lee Road  
Chantilly VA 22021
2. NFPA 70 (N.E.C.)  
NFPA-501C  
NFPA 58      National Fire Protection  
Association  
470 Atlantic Avenue  
Boston MA 02210
3. CSA Electrical  
Bulletin #946      Canadian Standards  
Association, Housing and  
Construction Materials  
Section  
178 Rexdale Blvd.  
Rexdale, Ontario,  
Canada M9W 1R3
4. California  
Administrative  
Code - Title 25  
Chapter 3      State of California  
Documents Section  
P.O. Box 1015  
North Highlands, CA  
95660

**This manual contains information that is subject to change. For this reason, use only the installation manual supplied with the generator set for the installation.**

**⚠WARNING Incorrect installation, service, or replacement of parts can result in severe personal injury, death and/or equipment damage. Service personnel must be qualified to perform electrical and/or mechanical component installation.**

## COMPONENT LOCATIONS

The standard control panel and routine maintenance items are located behind the access cover (Figure 1-1).

**To remove the access cover:** Rotate the fasteners on the access cover one-quarter turn clockwise

so the arrows point to the right. Pull the top of the cover away from the housing.

**To secure the access cover:** Position the bottom of the cover over the base. Push the top of the cover in and turn fasteners one-quarter turn counterclockwise so the arrows point up.

**⚠ WARNING** *Operation of the generator set with the access cover removed can result in severe personal injury or equipment damage. Hot components are exposed when the access cover is removed and generator set cooling air does not circulate properly. Do not operate the generator set with the access cover removed.*

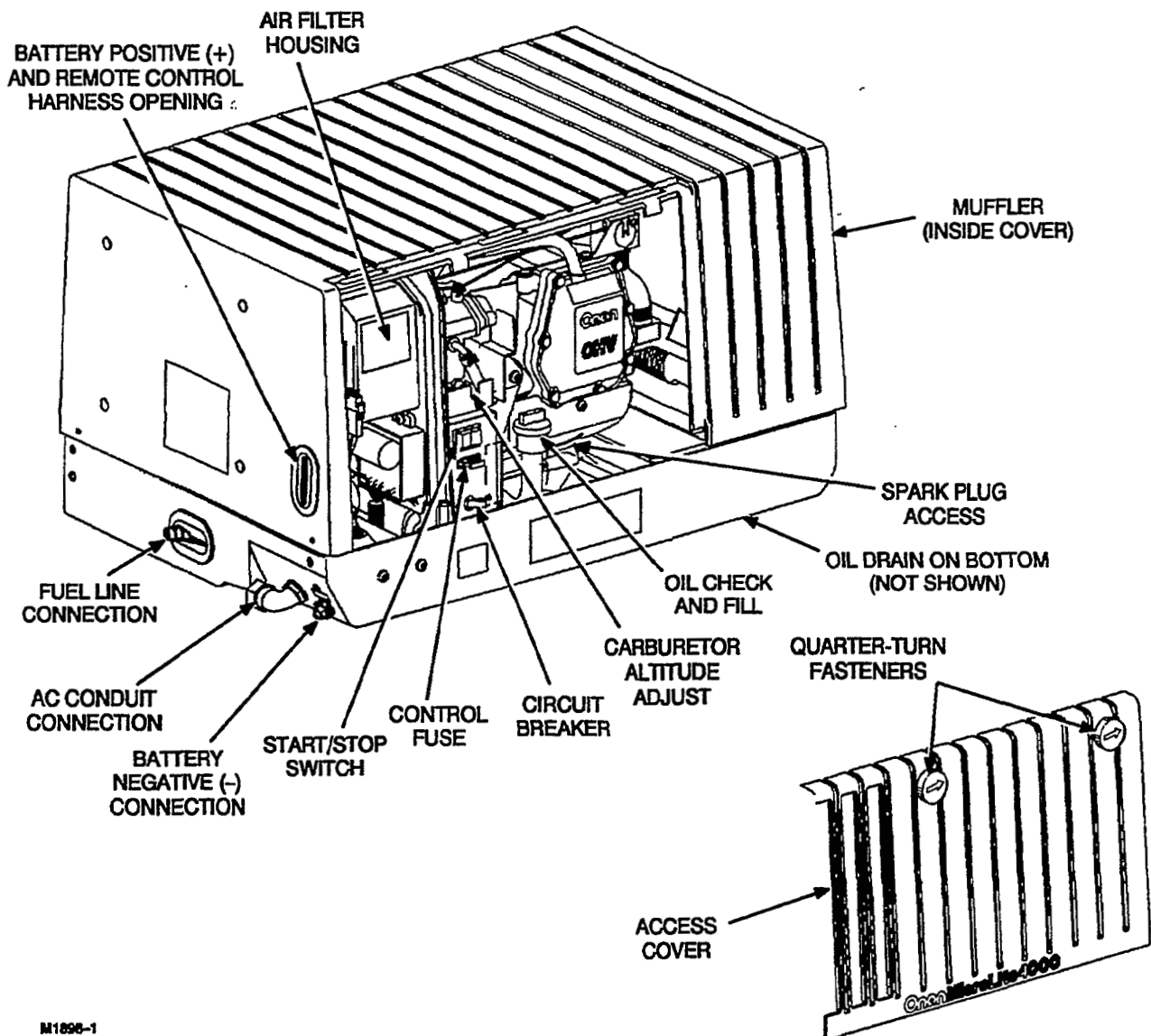

M1896-1

FIGURE 1-1. MICROLITE (KY) GENERATOR SET COMPONENT LOCATIONS



## 2. Specifications

MODEL	4000 KY	3600 KY (LP)
<b>GENERATOR</b>		
Generator Type	Onan®, Revolving Field, 2-Pole	Onan , Revolving Field, 2-Pole
Frequency (Hertz)	60	60
Power (Watts)	4000	3600
Voltage	120	120
Current (Amperes)	33.3	30
<b>ENGINE</b>		
Engine Model	Onan EO95H-G	Onan EO95H-G
Engine Type	4-Stroke, Single Cylinder, OHV	4-Stroke, Single Cylinder, OHV
Engine Speed	3600 rpm	3600 rpm
Ignition Type	Electronic Magneto (Breakerless)	Electronic Magneto (Breakerless)
Fuel	Gasoline	LPG Vapor (11 inches W.C.)
Engine Oil Capacity	1.7 qt (1.6 L)	1.7 qt (1.6 L)
Battery Requirements:		
Battery Size	12-Volt	12-Volt
Cold Cranking Amps	360 (450 Below 32°F [0°C])	360 (450 Below 32°F [0°C])
Spark Plug Gap	0.025 in. (0.64 mm)	0.025 in. (0.64 mm)
Average Fuel Consumption:		
No Load	0.15 gph (0.57 L/h)	0.35 gph (0.54 L/h)
Half Load	0.40 gph (1.51 L/h)	0.54 gph (2 L/h)
Full Load	0.66 gph (2.5 L/h)	0.82 gph (3.1 L/h)
<b>GENERATOR SET DETAILS</b>		
Dimensions:		
Length	30 in. (762 mm)	30 in. (762 mm)
Width	19.4 in. (493 mm)	19.4 in. (493 mm)
Height	13.8 in. (350.2 mm)	13.8 in. (350.2 mm)
Weight	168 lb (76.2 kg)	168 lb (76.2 kg)
Air Requirements:		
Combustion	19 ft³/min (0.54 m³/min)	19 ft³/min (0.54 m³/min)
Engine/Generator Cooling	300 ft³/min (8.5 m³/min)	300 ft³/min (8.5 m³/min)
Fuel Pump Lift	3 ft (0.91m)	—



# 3. Step-By-Step Installation Outline

## INTRODUCTION

This section is a step-by-step overview of a typical installation. This section includes:

- Preparation
- Compartment Mounting
- Under-Floor Mounting
- Connecting to Vehicle Systems
- Exhaust System

Review this section, then refer to the detailed instructions that are given in sections four through eight for specific procedures and important safety precautions before starting the installation. The installer is responsible for complying with all applicable installation codes and safety requirements.

## PREPARATION

1. Remove the wooden shipping crate by prying the bottom of the crate's sides and ends out from the wooden skid base. Carefully lift the crate off the genset and discard.

Remove the plastic bag covering the genset and collect loose shipped items, like the Operator's Manual, and add them to the vehicle documentation package.

2. Remove the mounting bolts that secure the wooden skid to the ends of the genset base.

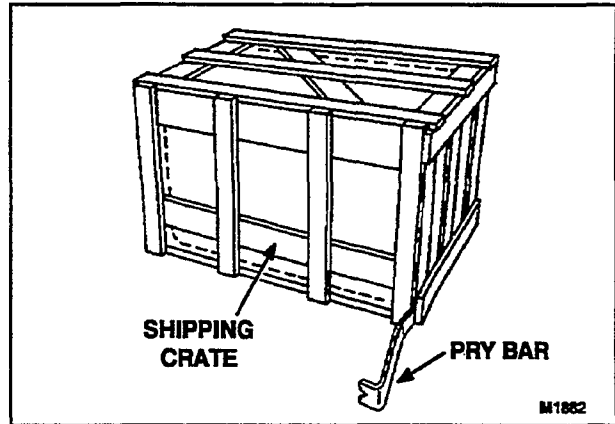

FIGURE 3-1. CRATE REMOVAL

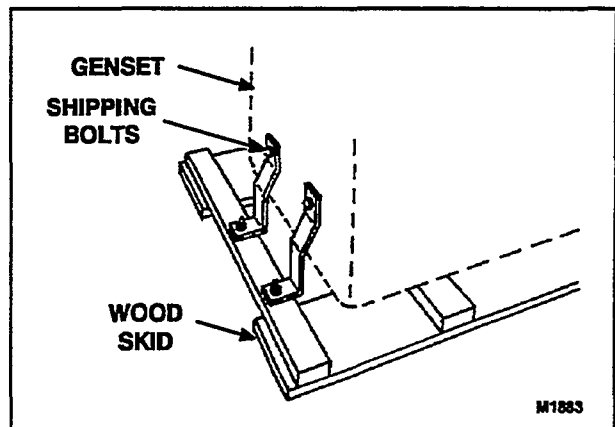

FIGURE 3-2. SKID BASE REMOVAL

## COMPARTMENT MOUNTING

Install the generator set in its own compartment. If any part of the compartment is above the vehicle floor, separate the compartment from the living quarters with vapor-tight walls. Refer to the *Mounting* section for compartment construction details.

Vehicles that are unusually sensitive to vibration may require secondary isolation and a larger compartment.

**⚠WARNING** Exhaust gases present the hazard of severe personal injury or death. Make the compartment walls vapor tight to the interior of the vehicle to prevent exhaust fumes from entering the living quarters.

The generator set requires an unobstructed air inlet of at least 40 square inches (258 cm<sup>2</sup>). Refer to the *Mounting* and *Ventilation* section for details. Provide an adequate genset access for maintenance (11.25 X 19.5 inch minimum opening) and service removal either through the door or out the bottom.

1. Carefully measure the compartment size to make sure there will be proper clearance for the generator set. Figure 3-3 shows the compartment dimensions. Add 1/2 inch to compartment depth if 1/2-inch insulation is used inside the door. Allowing one to two inches of added space on the left side of the compartment will make electrical and fuel connections easier.

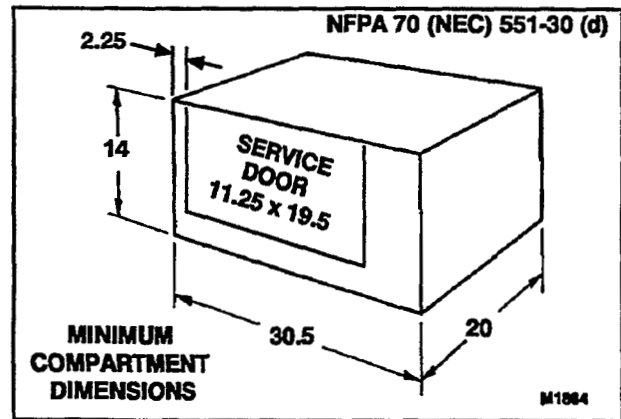

FIGURE 3-3. COMPARTMENT DIMENSIONS

2. Put holes in the bottom of the compartment for genset mounting, air outlet and oil drain (Figure 3-4). If the bottom of the compartment is wooden, remove the wooden section under compartment and replace it with a sheet metal floor and an adequate steel support frame. (Refer to Onan template number 539-1383).

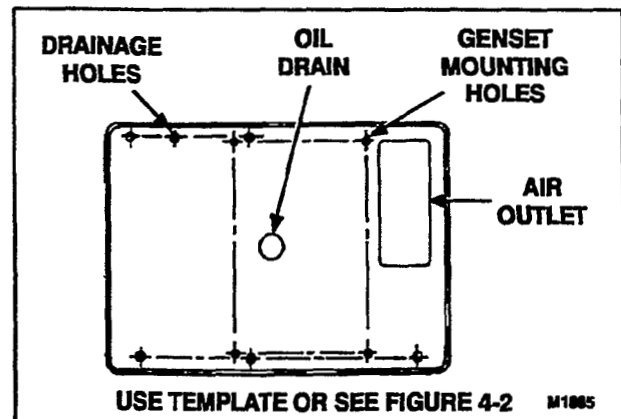

FIGURE 3-4. COMPARTMENT FLOOR TEMPLATE

- Put holes in the compartment to run connections for the fuel line, battery cable, remote control harness and AC conduit. Design holes so they will not chafe or restrict the lines.

If the remote control harness or AC conduit go directly into the interior of the vehicle, seal around the wires and inside the conduit to prevent the passage of exhaust gases. The fuel line must not be routed through the interior of the vehicle.

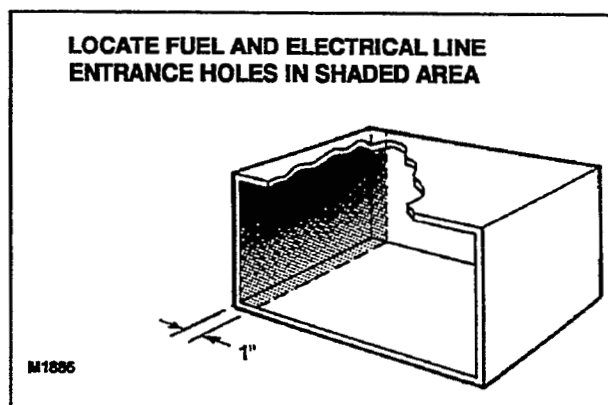

FIGURE 3-5. GENSET TO VEHICLE SYSTEMS CONNECTIONS

- Mount the generator set in the compartment with four 5/16-16 screws. Screw length must not protrude more than 1/2-inch (13 mm) through the genset base. The exposed above floor section of exhaust pipe must be shielded with the Onan-supplied exhaust shield.
- Proceed to Connecting To Vehicle Systems (page 3-5).

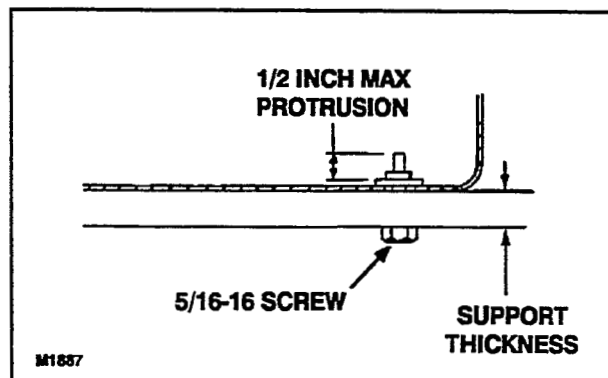

FIGURE 3-6. COMPARTMENT MOUNTING

### UNDER-FLOOR MOUNTING

An optional kit is required for under-floor mounting. Support brackets are used to suspend the genset below the floor of the vehicle. Refer to the instructions that are supplied with the kit for specific installation instructions and important safety precautions. For additional under-floor mounting information refer to the *Mounting* section.

- Use the template to locate the holes in the vehicle support structure. (Reference Onan template number 539-1382).

**⚠ WARNING** *Failure to provide an adequate support structure can result in severe personal injury, death, and/or equipment damage. Carefully follow the Under-Floor Housing kit installation instructions and provide an adequate support structure. Use specified hardware and tighten all mounting hardware to the recommended torque settings.*

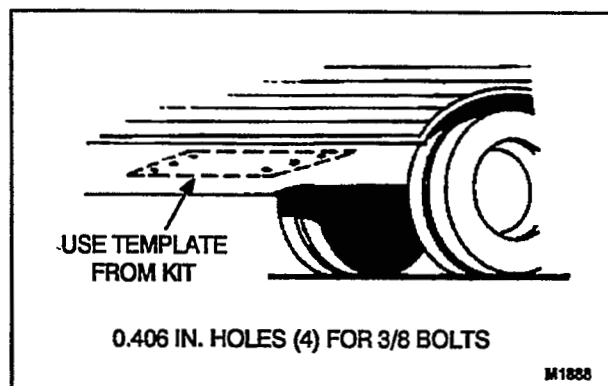

FIGURE 3-7. UNDER-FLOOR MOUNTING TEMPLATE

2. If the area above the compartment is made of a wood product, you must install a 26-gauge (0.02-inch) galvanized metal plate (or equivalent) above the genset.

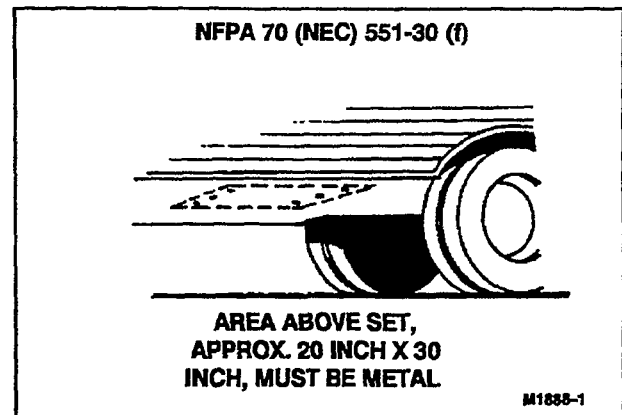

FIGURE 3-8. UNDER-FLOOR MOUNTING KIT WITH METAL CEILING (NOT SUPPLIED WITH KIT)

3. Assemble the Under-Floor Housing kit according to the instructions supplied with the kit. Securely mount hanger brackets and side panels to the under-floor support structure.

**⚠WARNING** *Dropping the generator set can cause severe personal injury or death. Make sure no one moves the vehicle during installation and keep feet and hands clear during installation.*

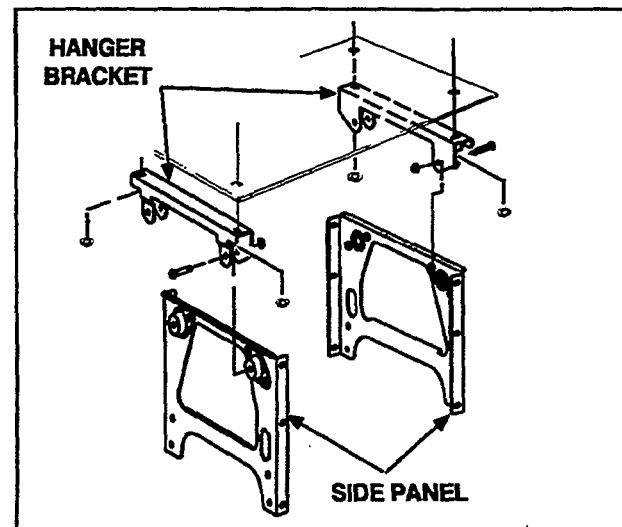

FIGURE 3-9. UNDER-FLOOR MOUNTING KIT

4. Assemble the front and back rails to the genset. Use a forklift to carefully raise the genset into position in the support frame. Secure the rails to the support frame with the mounting hardware included in the Under-Floor Housing kit.
5. Proceed to the next section on connecting to the vehicle systems.

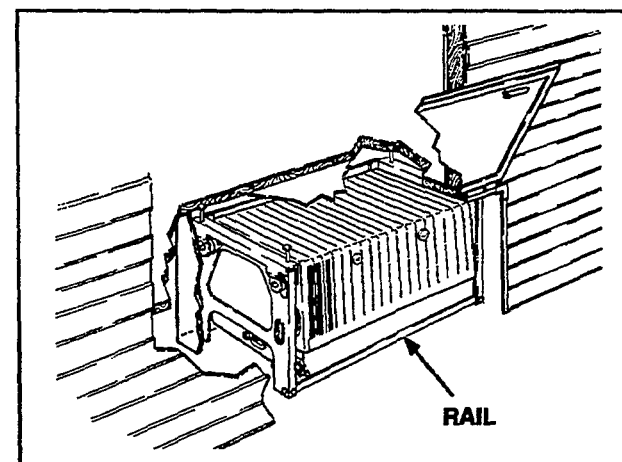

FIGURE 3-10. UNDER-FLOOR INSTALLATION

## CONNECTING TO VEHICLE SYSTEMS

1. Route fuel line separate from electrical wires or separate them with conduit or other sheathing.

**⚠WARNING** Fuel presents the hazard of fire or explosion that can result in severe personal injury or death. Do not smoke or allow any flame, spark, pilot light, arc-producing equipment or other ignition sources near fuel or in the installation area. Read the important safety precautions in the Fuel Systems section.

2. **Gasoline Fuel:** Connect 1/4-inch I.D. fuel hose (type SAE 30-R7) to the barb fitting on the generator set.  
**LPG Fuel:** Connect 3/8-inch I.D. fuel hose (see LPG Fuel System) to the barb fitting on the generator set.

Secure fuel hose to barb fitting with a stainless steel clamp (worm-gear type). Do not over tighten clamp or hose could be damaged.

3. Install a listed 1/2-inch flexible conduit over the AC wiring. (Use water-tight conduit for under-floor mounting.) Secure the conduit to the fitting on the generator set.

**⚠WARNING** Accidental starting can cause severe personal injury or death. Do not connect the battery cables to the genset starting battery until instructed to in the Initial Start and Checks section.

4. Remove the service access cover. Route the battery positive (+) cable through the access hole in the left side of the housing. Connect the battery positive (+) cable to the B+ connection on the start solenoid.

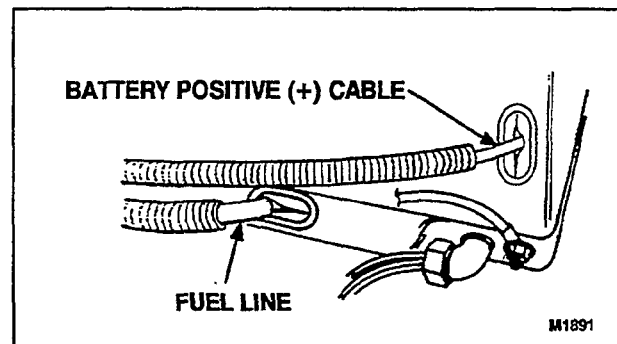

FIGURE 3-11. FUEL AND ELECTRIC LINES

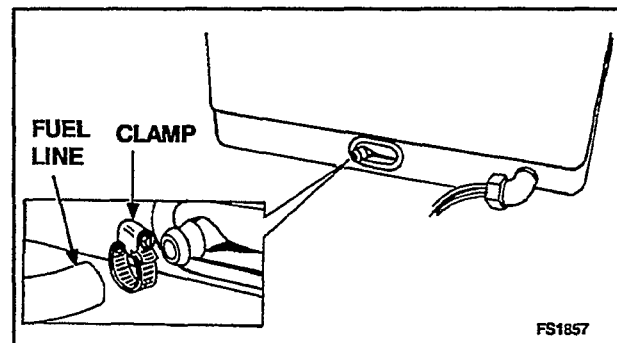

FIGURE 3-12. FUEL LINE CONNECTION

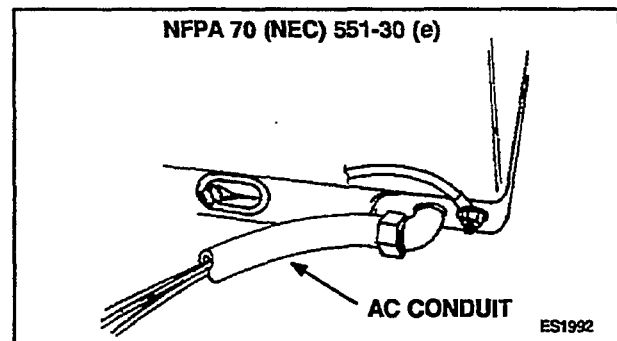

FIGURE 3-13. AC CONDUIT CONNECTION

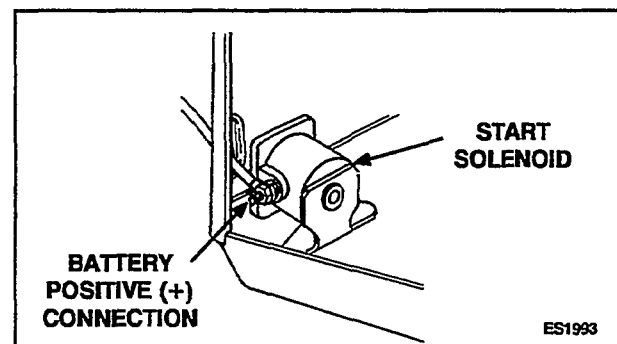

FIGURE 3-14. BATTERY POSITIVE (+) CONNECTION

5. Connect the battery negative (-) cable (with a 3/8-inch ring terminal) to the ground connection on the left side of the base. Refer to the Electrical Connections section for important genset grounding instructions.

**⚠WARNING** *Failure to ground the genset properly can result in injury or death. If the genset is not grounded to the vehicle chassis through the battery negative (-) cable, attach an 8 AWG equipment ground wire between the vehicle chassis and the battery negative (-) connection.*

6. Route the remote control connector through the access opening in the left side of the housing. Connect the remote control connector to the mating connector inside the genset.
7. Proceed to the next section on connecting the exhaust system.

## EXHAUST SYSTEMS

**⚠WARNING** *Exhaust gas presents the hazard of severe personal injury or death. Do not terminate the exhaust pipe under the vehicle. The exhaust pipe must not terminate so that any vent, window, or opening into the living area is within the triangular area shown in Figure 3-21. Read the Important safety precautions in the Exhaust Systems section.*

1. Connect the exhaust pipe (1 1/2-inch O.D. or 1 3/8-inch I.D., installer-supplied) to the genset with a U-bolt clamp. A short-radius exhaust elbow is supplied with the generator set for installations that require a tight turn of the exhaust pipe at the outlet. Use the Onan-supplied exhaust shield for compartment mount installations whenever the exhaust elbow is turned down for through-the-floor installations.

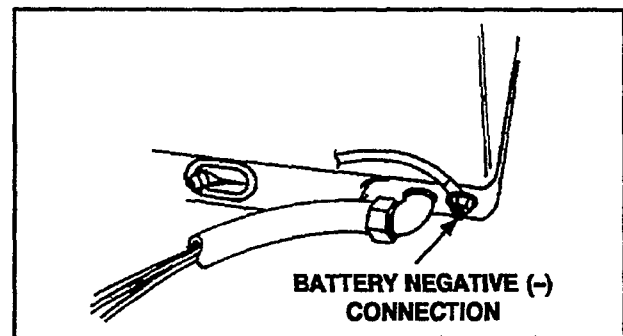

FIGURE 3-15. BATTERY NEGATIVE (-) CONNECTION

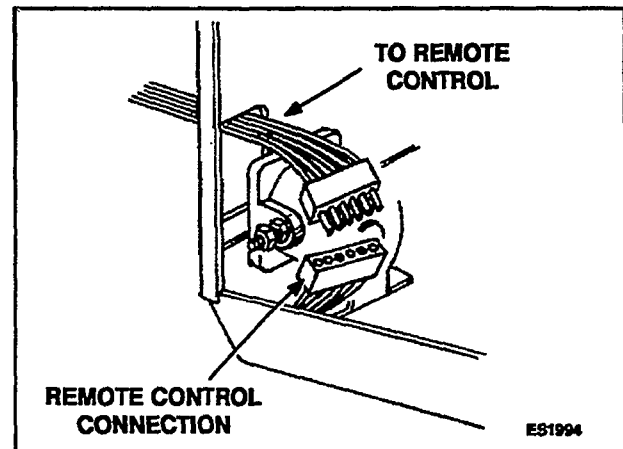

FIGURE 3-16. REMOTE CONTROL CONNECTION

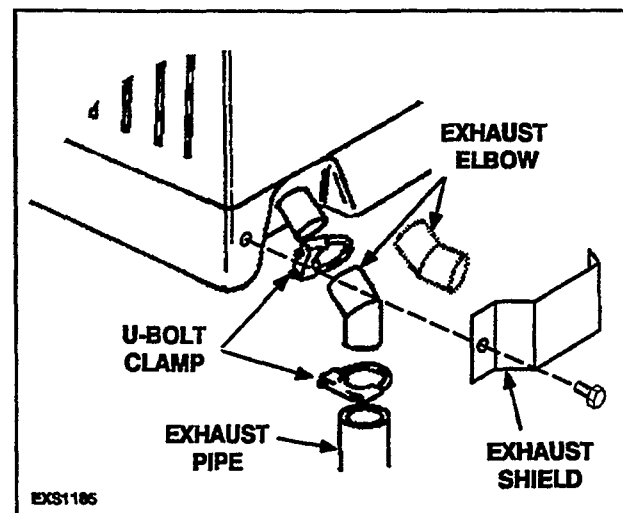

FIGURE 3-17. EXHAUST PIPE CONNECTION



2. Do not terminate the exhaust tail pipe under the vehicle. The exhaust tail pipe must terminate 1 inch (25.4 mm) beyond the side or end of the vehicle.

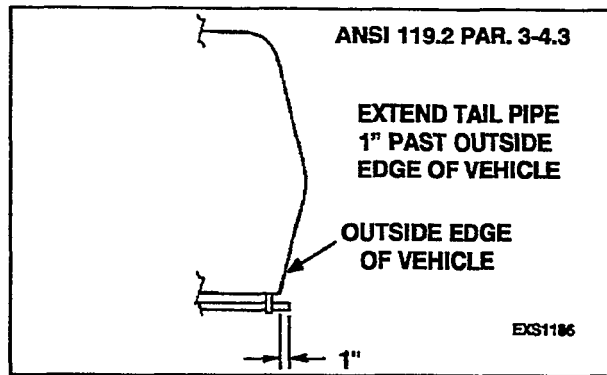

FIGURE 3-18. TAIL PIPE EXTENSION BEYOND VEHICLE

3. Support the tail pipe as close to the outside of the vehicle as possible.

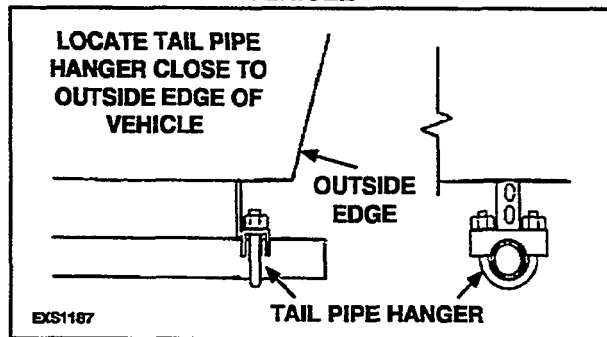

FIGURE 3-19. EXHAUST PIPE SUPPORT

4. Termination of the exhaust tail pipe below the angle of departure (lowest point on rear of vehicle to the tire ground contact point) must be protected by a skid bar, trailer hitch, or some frame member.

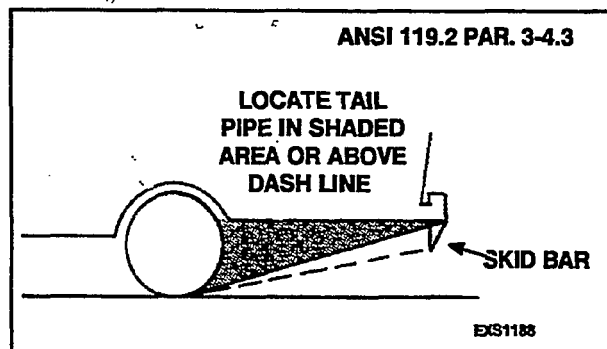

FIGURE 3-20. TAIL PIPE PROTECTION

5. Be aware that any vent, window, or opening that can be opened and that is not permanently sealed from the vehicle living space, can be an avenue for carbon monoxide. The tail pipe must not terminate so that any vent, window, or opening into the living area is within the triangular area shown in Figure 3-21.

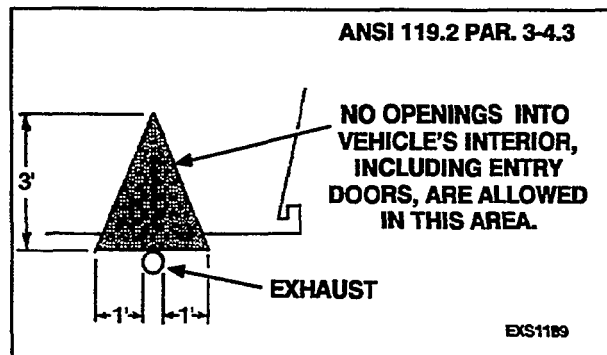

FIGURE 3-21. TAIL PIPE LOCATION

6. Refer to each of the sections in this manual for detailed installation instructions and for important safety precautions. Always follow the procedures in the Initial Start and Checks section when the installation is complete.



# 4. Mounting

## GENERAL

MicroLite generator sets are designed for either compartment or underfloor mounting. Choose the appropriate part of this section and carefully follow the instructions. Read any applicable kit instructions before installing the generator set.

## COMPARTMENT MOUNT

In a compartment mount, the genset is installed in a frame that is part of the vehicle. This frame must be constructed according to safety-approved specifications (see Compartment Construction in this section).

**Vehicles that are unusually sensitive to vibration may require secondary isolation and a larger compartment.**

Unless the set will be removed from underneath the vehicle, make the access opening large enough to remove the set. Allow enough clearance for removal of the access cover. See Figure 1-1.

Minimum compartment dimensions are shown in Figure 4-1. Clearances between the genset and the compartment are included in these dimensions.

Allow for air intake at the front left side of the set and air discharge at the bottom of the set. Air inlets to the set compartment must not allow dirt, rocks, water, or slush to reach the set. Minimize dust and salt entrance into the compartment. (See *Ventilation* section.)

Exposed above-floor section of exhaust pipe must be shielded with the Onan-supplied exhaust shield.

### Compartment Construction

1. Install the gen set in its own compartment. Allow a minimum of 1/4-inch (6.4 mm) clearance at the front, sides, back and top of the set. See Figures 4-1 and 4-2.

Allow additional front (service side) clearance if the vehicle air inlet is not aligned with the genset air inlet, to obtain the minimum free air inlet of 40in<sup>2</sup> (258 cm<sup>2</sup>).

**Example:** If the air inlet is along the entire bottom front edge of the compartment, increase the front clearance to 1-1/3 inches (34 mm).  
40 in<sup>2</sup> ÷ 30 in (air inlet length) = 1-1/3 in.

If insulation is used to line the compartment, increase the compartment size to include the width of the insulation.

2. If any part of the compartment is above the vehicle floor, separate the compartment area from the living quarters and fuel supply with vapor-tight walls.
3. Line the compartment walls with 26-gauge galvanized steel or a material of comparable strength and fire resistance (see NFPA 70, NEC and California Title 25 for complete details).

**⚠ WARNING Exhaust gases present the hazard of severe personal injury or death. Make the compartment walls vapor-tight to the interior of the vehicle to prevent exhaust fumes from entering.**

4. Construct a compartment floor that will prevent oil, fuel or water accumulation. Provide openings in the compartment floor according to the Compartment Floor Plan, Figure 4-2.

Do not use absorbent soundproofing material on the compartment floor or oil and gas could cause a fire hazard. The floor should have as few openings as possible, to reduce the noise level.

5. Equip the base with an oil drain hole to the outside of the compartment. Do not mount the exhaust pipe below the oil drain hole.

**⚠ WARNING Fire presents the hazard of severe personal injury or death. Do not position the exhaust pipe directly below a drain hole. Hot exhaust can ignite fuel or oil.**

6. Secure the genset mounting base to the support frame with four 5/16-18 UNC grade 5 screws. The mounting bolts must not extend more than 1/2 inch (13 mm) into the base. See Figures 4-1 and 4-2. Torque 5/16 inch mounting screws to 15 ft lbs (20 N•m).

**⚠ CAUTION If the mounting base is not fastened securely to the vehicle compartment, road vibration will damage the genset components. Use long enough screws for at least 1-1/2 threads to extend through the weld nut. The mounting bolts must not extend more than 1/2 in. (13mm) into the base.**

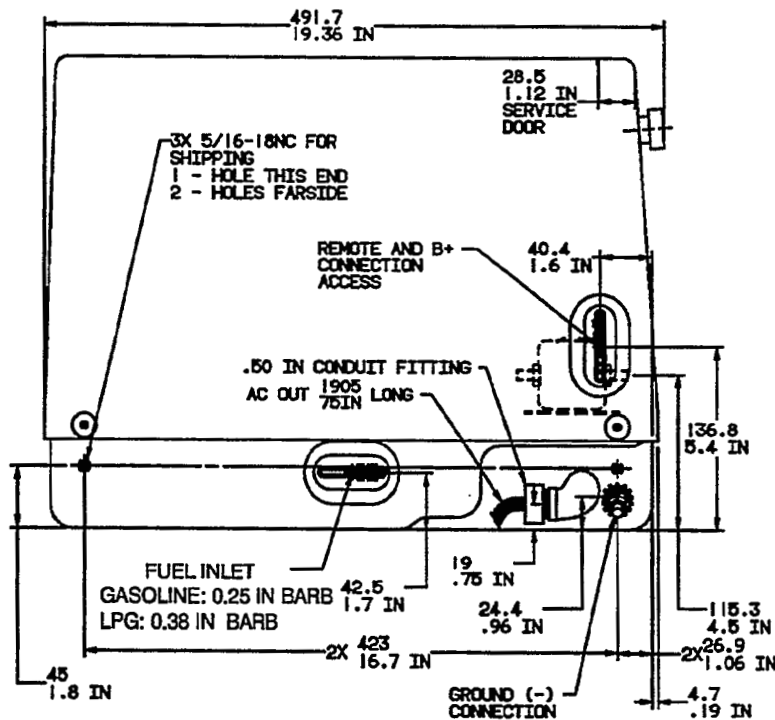
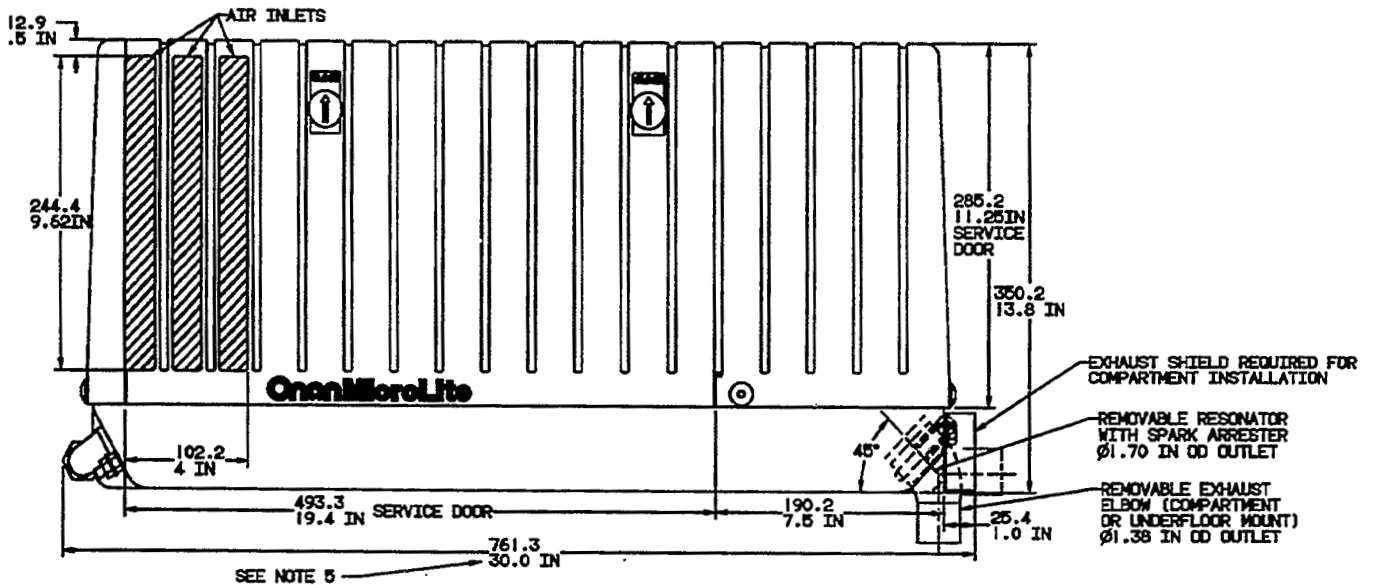

**NOTES:**

1. PRIMARY DIMENSIONS ARE MILLIMETERS.
2. COMPARTMENT ACCESS SHALL ALLOW REMOVAL AND REPLACEMENT OF SERVICE DOOR AND ACCESS TO THE FOLLOWING SERVICEABLE COMPONENTS:  
 START-STOP SWITCH, FUSE CIRCUIT BREAKER  
 OIL FILL AND CHECK  
 AIR CLEANER ELEMENT  
 CARB AND CHOKE ADJUSTMENTS  
 SPARKPLUG, VALVE COVER
3. MIN UNIT CLEARANCE FROM COMPARTMENT SURFACES:  
 TOP 6.4 .25 IN  
 ENGINE END 6.4 .25 IN  
 GEN END 6.4 .25 IN  
 SERVICE SIDE \*\* 6.4 .25 IN  
 BACKSIDE 6.4 .25 IN  
 MIN FREE AIR INLET 258CM<sup>3</sup> 40IN<sup>3</sup>  
 UNIT WEIGHT 76.2KG 168LB
- \*\* SERVICE SIDE CLEARANCE OF .25 IN REQUIRES DIRECT ALIGNMENT OF SET AIR INLET AND OPENING IN ACCESS DOOR. IF COMPARTMENT AIR INLET IS LOCATED ELSEWHERE, 1.50 IN MIN IS REQUIRED BETWEEN SET AND ACCESS DOOR TO MAINTAIN 40 IN<sup>3</sup> FREE AIR INLET
4. EXHAUST PIPE SHIELD MUST BE USED FOR COMPARTMENT INSTALLATIONS. FOR UNDERFLOOR INSTALLATIONS IT MAY BE REMOVED.
5. MINIMUM INSTALLATION SIZE IS LARGER AND VARIES WITH MOUNTING KIT USED

FIGURE 4-1. COMPARTMENT OUTLINE DRAWING

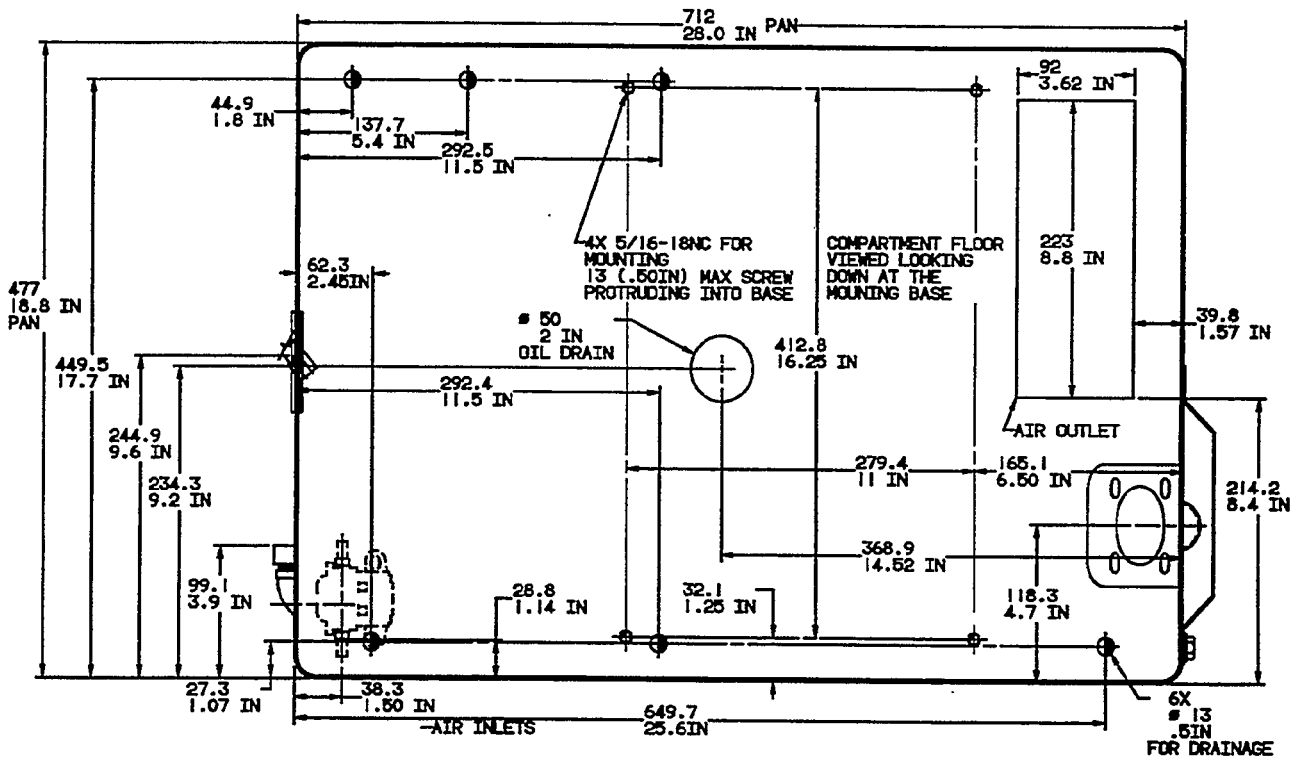

DRAWING NOTES  
ON PAGE 4-2

FIGURE 4-2. COMPARTMENT FLOOR PLAN

## UNDER-FLOOR MOUNT

In an under-floor installation, the generator set is mounted below the floor and outside the passenger compartment of the vehicle. This type of installation must comply with the Installation Codes and Safety Recommendations (see *Introduction* section). Read this section for general application information, and study the under-floor housing kit instructions for more information on under-floor installations and important safety precautions.

The vehicle structure must be able to support the weight of the generator set (see *Specifications* section). The vehicle manufacturer and/or the installer must provide a structurally sound support frame, using tubing, angle brackets, or steel-reinforced plywood or other composition board. Plywood or particle board can be reinforced with 3-inch (76 mm) or larger washers or a full metal plate.

If the generator set will be installed below a wooden floor, a metal barrier must be installed between the wooden floor and the generator set.

Use 26-gauge (0.0217 inch) painted or galvanized sheet metal or a material of comparable strength and fire resistance (see NFPA 70, NEC and California Title 25 for complete details).

Under-floor mounted sets do not require the exhaust pipe heat shield.

**WARNING** *Fire presents the hazard of severe personal injury or death. Install a metal barrier between the generator set and any wooden or flammable parts of the vehicle.*

### Generator Set Location

Figure 4-3 shows the most common mounting areas for a generator set. Protect the generator set from road splash and debris. If possible, drive the vehicle through mud and slush to test the installation.

Leave a minimum space of 1-1/2 inches (38.1 mm) between the generator set and the vehicle skirt for an air inlet if a side air inlet is not aligned with the genset air inlet. Provide a minimum back, top, and side clearance of 0.25 inches (6.4 mm).

The air inlet opening to the generator set compartment must not admit dirt, rocks, water or slush. The entrance of dust and salt into the compartment must be minimized. Baffles may be needed to protect certain areas. See the *Ventilation* section of this manual for more detailed information.

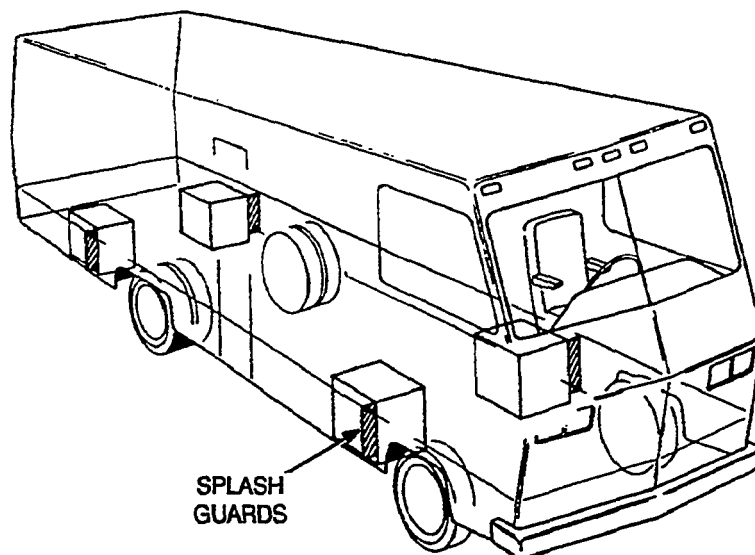

M1742

FIGURE 4-3. COMMON GENERATOR SET MOUNTING AREAS

---

**Mounting Brackets:** The vehicle must be adapted for use with the under-floor mounting bracket kit. The construction of the vehicle must support the weight of the generator set (see *Specifications* section). It is the vehicle manufacturer and/or the installer's responsibility to provide hardware to attach the mounting brackets.

Review the *Exhaust System* section. Plan clearances for moving or removing exhaust components when the set is removed for service.

**Access Opening:** Provide an access opening to the generator set on the side of the vehicle. Make the access large enough to allow for removal of the generator set access cover. Also allow access to the oil drain located at the bottom of the set, so the generator set does not have to be removed for servicing (see Figure 1-1 for service locations).





# 5. Ventilation and Acoustics

## VENTILATION

The most important factors of ventilation for an air cooled generator set are sufficient incoming air (for combustion and cooling) and adequate exhausting of heated air.

A fan draws cooling air through the inlet on the generator end and pushes it across the generator and engine cooling fins. The heated air is expelled through the air outlet on the bottom of the set. See Figure 5-1.

Make certain that nothing obstructs or restricts the air intake and air outlet. Air recirculation must be minimized. If a noise or dust deflector are added to the set, it must be located a minimum of 6 inches (150 mm) below the generator set and it must be open on three sides.

**⚠WARNING** Exhaust gas presents the hazard of severe personal injury or death. Because discharged cooling air can contain deadly exhaust gas, never use discharged cooling air to heat the vehicle.

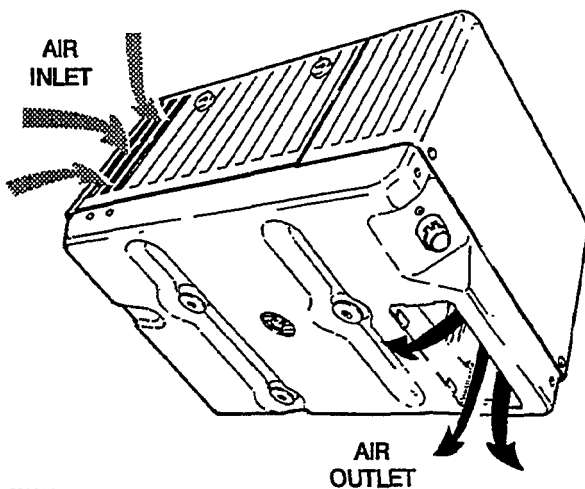

FIGURE 5-1. COOLING AIRFLOW

**⚠CAUTION** Operating the generator set with the cover removed can cause equipment damage. Generator set cooling air does not circulate properly with the access cover removed. Do not operate the generator set with the access cover removed.

When designing the air inlet and outlet for the set compartment (see Figures 4-1 and 4-2), allow for the restriction of grilles and ductwork: some expanded metal grilles provide only 60 percent free-air inlet area per square foot. The most efficient grille provides only 90 percent free inlet area per square foot. Obtain the free inlet area of the grille material from the material supplier. Multiply the grille area by the free area percentage to get the free inlet area. The minimum size of the free air inlet is 40 in<sup>2</sup> (258 cm<sup>2</sup>). The compartment size, air inlet opening size and grille design must meet the minimum air inlet opening requirements.

Air ducting must provide a direct free-airflow path to the generator set, with minimal bends. The duct must be smooth and non-restrictive to airflow.

Air inlet openings should be located as high as possible to allow for convection cooling of heated air from the generator set compartment after unit shutdown. Otherwise, hard starting could result from vapor locking, hot combustion air, etc.

**⚠WARNING** Fuel and fuel leakage present the hazard of fire or explosion, which can cause severe personal injury or death. The ventilation system should provide a constant flow of air to expel any accumulation of fuel vapor. The generator set compartment must be vapor-tight to the vehicle interior, to keep fumes from entering the vehicle.

Locating the free air inlet opening in the vehicle skirt or side access door is recommended. If the vehicle skirt does not extend to or below the bottom of the generator set, provide an extension. Inlet air taken from below the vehicle must come from the skirt side of the compartment.

## ACOUSTICS

The genset is designed to minimize noise levels. If additional noise reduction is required, line the top and sides of the genset compartment with a 1 inch (25.4 mm) thickness of sound absorbing material. The optional exhaust resonator can also be used to lower the noise level. Locating the air inlet away from the genset air inlet opening will reduce the noise level; however, additional compartment space will be required (see Compartment Mounting in the *Mounting* section). See the following guidelines to construct the housing.

- Make certain that all joints and corners of the compartment are vapor-tight to the interior/cab of the vehicle. Lining the compartment is less effective if openings, cracks, doors and joints are not sealed. Seal the compartment door edge to eliminate noise leaks around the door perimeter.

- Cover the back, top and sides of the compartment (not the compartment base) with fiberglass or other self-extinguishing, sound-absorbent material. Sound insulation and adhesive should be rated at 200°F (90°C) minimum. See Figure 4-2 to design the set compartment for optimum noise reduction.
- A combination of materials can reduce noise more than a single material can. For instance, a sheet of lead combined with a layer of acoustical material is more effective than either one alone.

**⚠WARNING** *High temperatures in the compartment can present the hazard of fire, which can result in severe personal injury or death. To meet ANSI and CSA temperature rise requirements for vehicles, the layer of insulation must not reduce the minimum compartment size specified in Figure 4-1.*

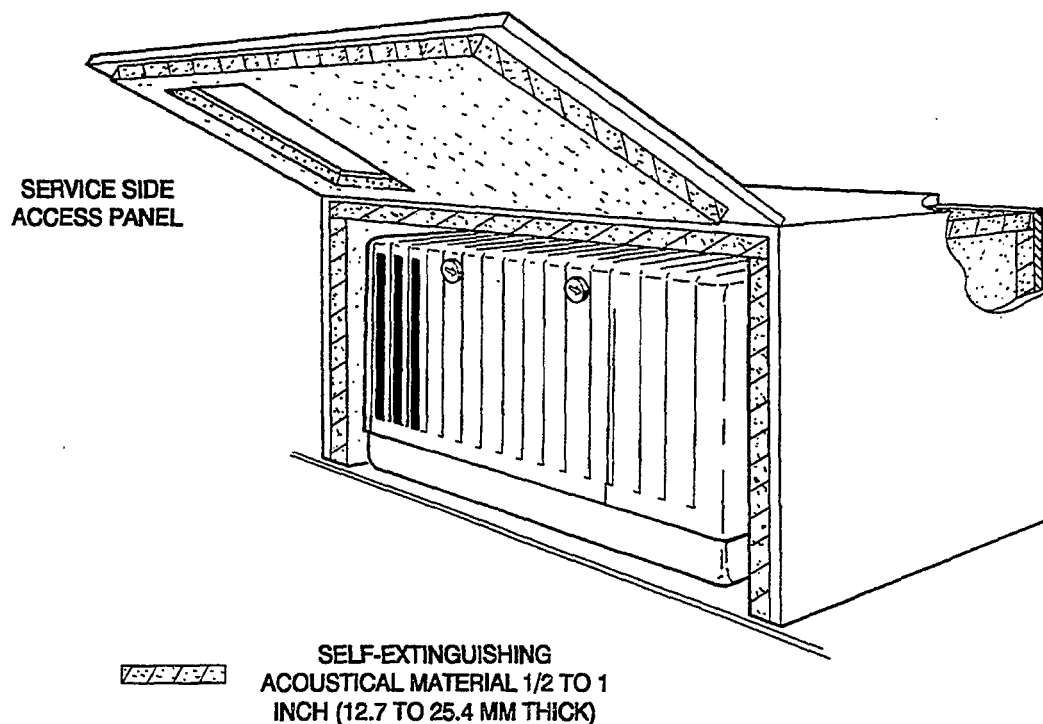

M1799-1a

FIGURE 5-2. NOISE REDUCTION COMPARTMENT DESIGN

# 6. Exhaust System

---

## GENERAL

Plan the exhaust system carefully. A proper installation is not only vapor-tight, it is also quieter and safer. Use the Onan-supplied exhaust shield for compartment installations whenever the exhaust elbow is turned down for through-the-floor installations. The exhaust shield can be discarded for under-floor installations. The exhaust system installation must comply with all applicable standards, local codes and regulations. Study the following recommendations.

## MUFFLER RECOMMENDATIONS

The Onan-installed spark arrester muffler is U.S. Forest Service-approved, and meets code requirements. Failure to provide and maintain a spark arrester can be a violation of the law.

Liability for damage or injury, and warranty expenses due to use of unapproved mufflers or installation modifications becomes the responsibility of the person installing the substitute muffler or performing the modifications. Contact an Onan distributor for approved exhaust system parts.

## EXHAUST INSTALLATION GUIDELINES

The exhaust system must be placed no closer than 3 inches (76 mm) from combustible material (wood, felt, cotton, organic fibers, etc.), or be so located, insulated or shielded that it does not raise the temperature of any combustible material more than 117°F (65°C) above the ambient air inlet temperature.

The exhaust system must extend a minimum 1 inch (25 mm) beyond the perimeter of the vehicle. Do not terminate the exhaust tailpipe under the vehicle. Be aware that any vent, window, storage compartment or opening that can be opened and that is not permanently sealed from the vehicle living space can be an avenue for carbon monoxide.

The tailpipe must not terminate so that any vent, window, or opening into the living area is within the triangular area shown in Figure 6-1. This area is defined as an isosceles triangle with a height of 3 feet measured from the tailpipe termination and

with a base of 2 feet measured one foot horizontally from the pipe in either direction.

**⚠ WARNING** *Exhaust gas presents the hazard of severe personal injury or death. Do not terminate an exhaust pipe under the vehicle. The tailpipe must not terminate so that any vent, window, or opening into the living area is within the triangular area shown in Figure 6-1. Keep all openings closed when the generator set is running.*

To reduce the chance of damaging the tailpipe and emitting exhaust gases under the vehicle, make certain that no part of the exhaust system intrudes into the departure angle or approach angle of the vehicle, unless it is protected by a skid bar or other protection device. The shaded areas in Figure 6-1 illustrate typical mounting locations.

**⚠ WARNING** *Exhaust gas presents the hazard of severe personal injury or death. Do not mount any portion of the exhaust system into the approach or departure angle unless it is adequately protected. Use only Onan-specified exhaust equipment with the generator set. Use a sufficient number of hangers to prevent dislocation of the system.*

## TAILPIPE RECOMMENDATIONS

An exhaust tailpipe is not supplied with the generator set because length requirements vary between vehicle manufacturers. A short-radius exhaust elbow is supplied with the generator set for installations that require a tight turn of the exhaust pipe at the outlet. Refer to the following recommendations for information and safety considerations.

Use 1-1/2 inch O.D. (1-3/8 inch I.D.) 18-gauge aluminum steel or stainless steel tubing for tailpipe.

**⚠ WARNING** *Exhaust gas presents the hazard of severe personal injury or death. Do not use flexible exhaust tailpipe, because it can leak or break from road shock or vibration. Do not terminate the exhaust system under the vehicle. Direct exhaust gases away from any window, door, or compartment openings. Do not operate the generator set without an exhaust tailpipe.*

Use a 1-3/8 inch U-bolt type automotive muffler clamp to connect the exhaust tailpipe to the exhaust elbow.

If the tailpipe extends more than 1-1/2 feet (0.46 m) from the generator set, attach an automotive tailpipe hanger for additional support. Also use additional automotive type tailpipe hangers every 2 to 3 feet (0.6 to 0.9 m) of tailpipe run. Always support the exhaust system at or near the perimeter of the vehicle to prevent the pipe from being damaged and pushed up under the vehicle

skirt. Attach hangers to steel framework, not wood or other floor materials. Refer to Figures 6-2 and 6-3 for typical tailpipe installations.

**CAUTION** Excessive exhaust back pressure can cause engine damage. If a tailpipe deflector is used, make sure it is large enough to prevent back pressure.

**CAUTION** Water vapor can cause engine damage. Do not connect the generator set exhaust to the vehicle exhaust system, because water vapor from one engine can damage the other.

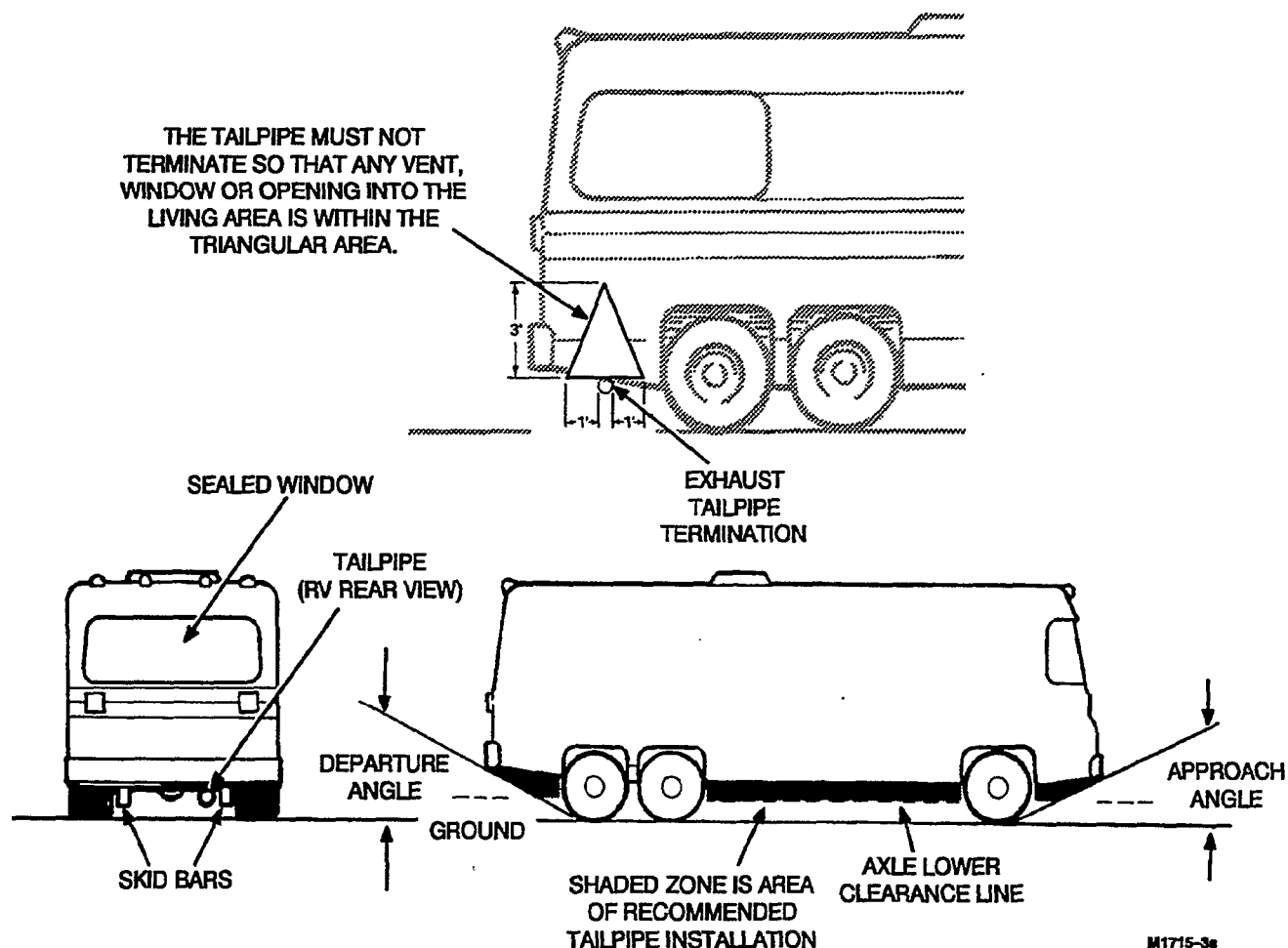

FIGURE 6-1. TAILPIPE INSTALLATION

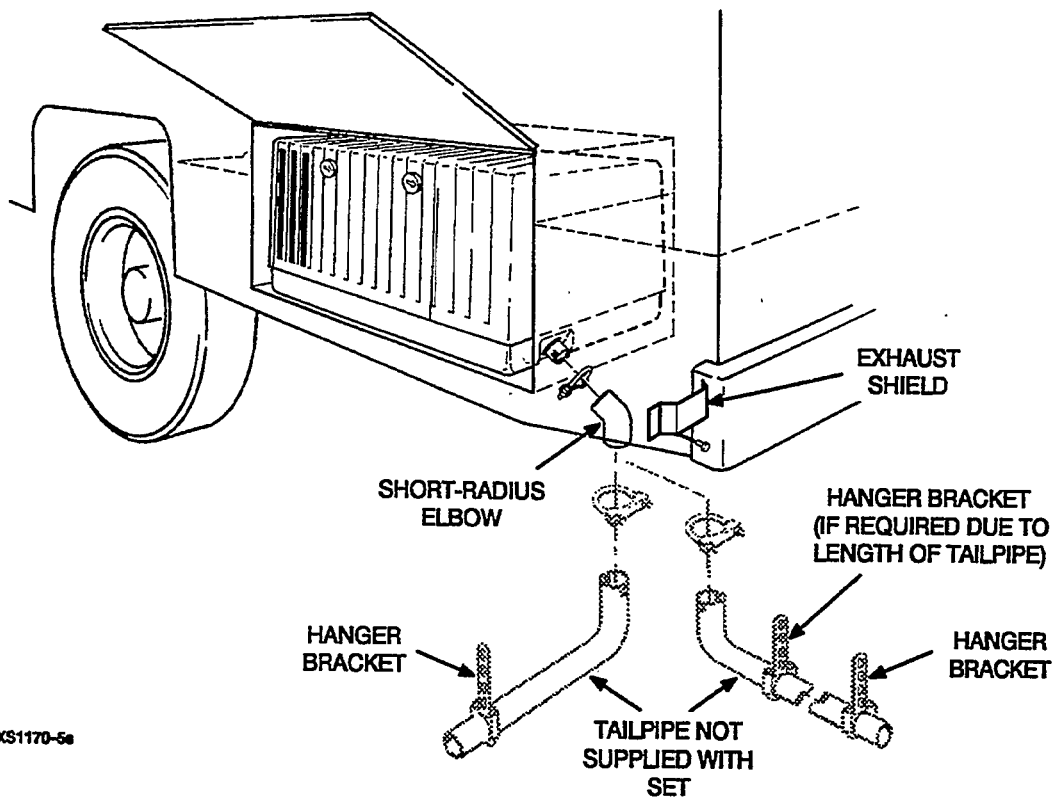

FIGURE 6-2. EXHAUST SYSTEM EXAMPLES FOR COMPARTMENT MOUNT INSTALLATIONS

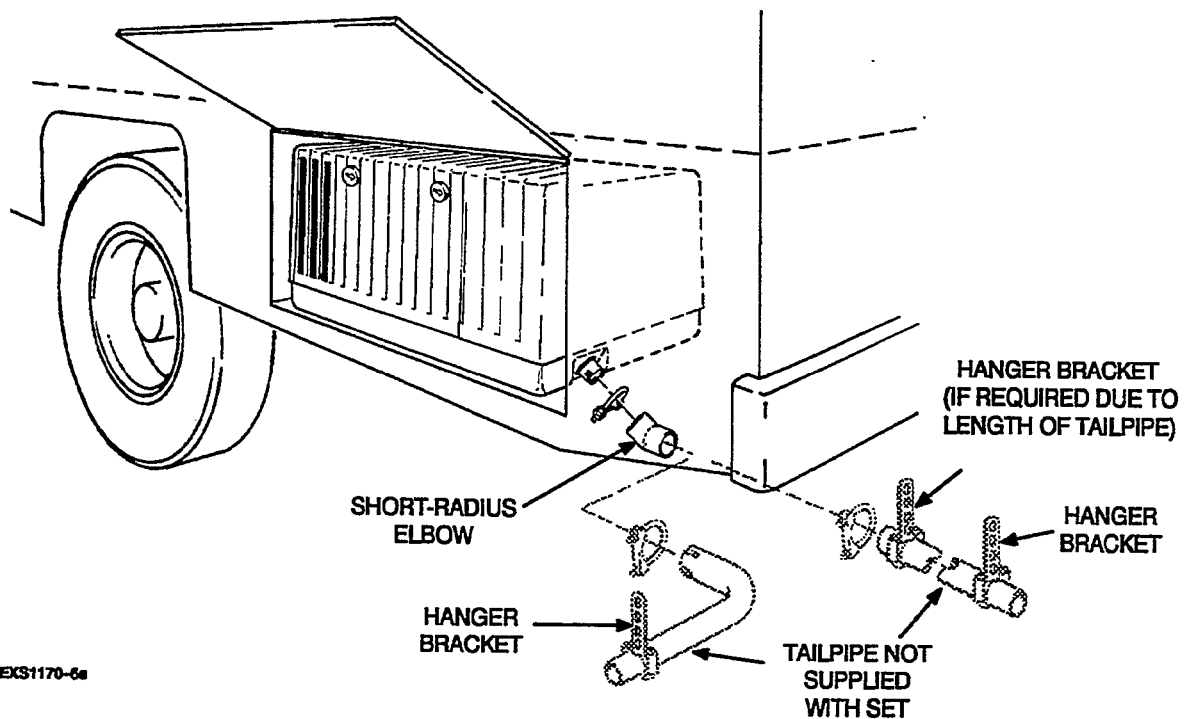

FIGURE 6-3. EXHAUST SYSTEM EXAMPLES FOR UNDER-FLOOR MOUNT INSTALLATIONS



# 7. Fuel System

---

## GENERAL

This section describes fuel system installations for recreational vehicles.

**⚠WARNING** *Fuel presents the hazard of fire or explosion that can result in severe personal injury or death. Do not smoke or allow any flame, spark, pilot light, arc-producing equipment or other ignition sources around fuel or fuel components, or in the installation area. Keep a type ABC fire extinguisher nearby. The ventilation system must provide a constant flow of air to expel any accumulation of fuel vapor while the vehicle is in transit. Compartments must be vapor-tight to the vehicle interior to prevent any fumes from entering these areas.*

## FUEL SYSTEM

### Fuel System Provisions

Use a separate fuel pickup tube or a separate fuel tank. Do not tie into the vehicle fuel supply line. On some vehicles, the generator set can share the vehicle fuel supply tank with the vehicle engine. Connection to the vehicle fuel tank must be made according to the chassis (vehicle) manufacturer's detailed instructions. See Fuel Line Installation, in this section.

The fuel pump has an integral fuel shutoff valve as a safety feature. If the vehicle fuel tank becomes pressurized (3 psi maximum), the positive fuel shut-off prevents the engine from being flooded when the genset is not running. The vehicle fuel tank gas cap should relieve pressure at 1-1/2 psi.

### Recommended Fuel

Use clean, fresh regular grade gasoline.

**⚠WARNING** *Fuel presents the hazard of fire or explosion that can cause severe personal injury or death. Never fill the fuel tank when the engine is hot or is running. Do not permit any flame, spark, pilot light, cigarette or other ignition source near the fuel system.*

### Fuel Consumption

Generator set fuel consumption varies proportionately to differing electrical loads. Refer to the *Specifications* section for approximate fuel consumption at no load, half load, and full load.

### Fuel Line Installation

Vehicle fuel systems operate at a specified fuel pressure. For this reason, do not change or remove the fuel fill tube, fill limiter vent, vapor canister, vapor lines, filler cap and all parts of the fuel system without the approval of the vehicle manufacturer. Check the filler cap to make sure that the pressure vacuum relief valve functions properly at 1-1/2 psi: replace it if necessary.

**Do not tie the generator set fuel line into the vehicle fuel supply line.** Unauthorized fuel system modifications can cause dangerous operating conditions.

- Tying a generator set fuel line into a **vacuum** supply line (vehicle fuel pump at the engine) can cause the generator set to starve for fuel at highway speeds or during acceleration.
- Tying a generator set fuel line into a **pressure** supply line (vehicle fuel pump in the fuel tank) can cause poor generator set operation and create a hazard of fire or explosion caused by fuel leakage.

Some vehicle manufacturers permit tying into the fuel **return line** on high pressure fuel systems. Contact the vehicle manufacturer for details and approval. The fuel return line pressure at the point of connection must not exceed 1-1/2 psi, or carburetor flooding could result.

**⚠WARNING** Gasoline presents the hazard of explosion or fire, which can result in severe personal injury or death. Do not connect the generator set fuel line to the pressurized part of the vehicle fuel system. Flooding of the generator set engine and compartment can occur, resulting in a fire hazard.

**⚠CAUTION** The generator set could starve for fuel when the vehicle is operated at highway speeds if its fuel line is connected to the main fuel line with a tee. The generator set fuel pump has neither the capacity nor the power to overcome the draw of the vehicle engine fuel pump. For this reason, use a separate fuel line to the generator set, or use a separate fuel tank.

If a separate connection is not supplied for the genset, add a second fuel pickup in the tank. This pickup should not extend below the bottom 1/4 of the tank, so the vehicle will run after the generator runs out of fuel.

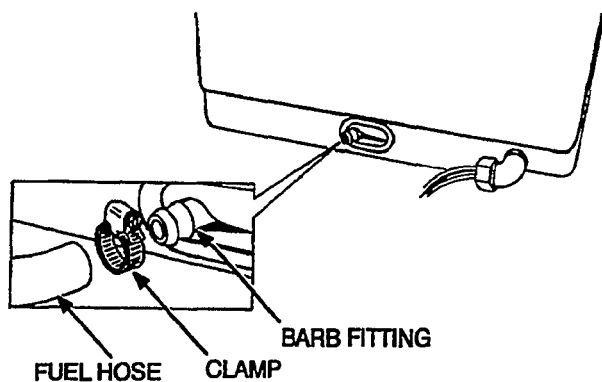

FIGURE 7-1. FUEL LINE CONNECTION

Connect 1/4-inch I.D. fuel hose (type SAE 30-R7) to the barb fitting on the generator set (Figure 7-1). Secure fuel hose to barb fitting with a stainless steel clamp (worm-gear type). Do not over tighten clamp or hose could be damaged. Fuel hose must be long enough to allow generator set movement, and prevent binding, stretching or breaking.

Onan recommends copper or hot dip coated seamless steel tubing (conforming to ASTM A-254) and double flared connections for long runs between the fuel tank and the flexible connector to the generator set.

Run fuel line at the same height as the top of the fuel tank (or above the tank) to a point as close to the genset as possible. This reduces the danger of fuel siphoning out of the tank if the line should break. The maximum fuel pump lift of the genset is 3 feet (0.91m).

Keep fuel lines away from hot engine or exhaust areas, to reduce the chance of vapor lock. Fuel lines should be accessible and protected from damage. Use metal straps without sharp edges to secure fuel lines. Do not run fuel lines where they may contact sharp or rough surfaces, or where they may be kinked, pinched, chaffed, or struck.

**⚠WARNING** Gasoline fuel may be accidentally ignited by electrical sparks, presenting the hazard of fire or explosion, which can result in severe personal injury or death. For this reason, when installing the generator set:

- Do not tie electrical wiring to fuel lines.
- Do not run electrical lines and fuel lines through the same compartment openings.
- Keep electrical and fuel lines as far apart as possible.
- Place a physical barrier between fuel lines and electrical lines wherever possible.
- If electrical and fuel lines must pass through the same compartment opening, make certain that they are physically separated by running them through individual channels, or by passing each line through a separate piece of tubing.



---

## LPG FUEL SYSTEM

### Fuel System Provisions

The LPG models are designed to operate on LP Vapor at 6 to 8 ounces per square inch (10 to 14 inches of water column). A regulator must be installed between the fuel cylinder and the genset that reduces the cylinder pressure to 6 to 8 ounces per square inch (10 to 14 inches of water column).

**⚠WARNING** *LPG fuel presents the hazard of explosion or fire that can result in severe personal injury or death. Do not connect the genset fuel line directly to the LPG fuel cylinder or fuel leakage could result from excessive fuel inlet pressure. A regulator must be used between the genset and the fuel cylinder that reduces cylinder pressure to 11 inches of water column.*

LPG genset operation is highly sensitive to variations in altitude, temperature, and fuel BTU content. For this reason, the fuel system may need to be adjusted after installation. Refer to the Service Manual if adjustments are required.

### Recommended Fuel

Use commercial propane or HD-5 grade LPG in a mixture of at least 90 percent propane. Propane fuels other than HD-5 may contain more than 2.5 percent butane, and may cause poor engine starting in low temperatures (below 32° F or 0° C).

### Fuel Consumption

Generator set fuel consumption varies proportionately to differing electrical loads. Refer to the *Specifications* section for approximate fuel consumption at no load, half load, and full load.

### Propane Fuel Lines and Supply Tank

**⚠WARNING** *LP gas (Propane) presents the hazard of fire or explosion that can cause severe personal injury or death. Do not permit any flame, spark, pilot light, cigarette, or other ignition source near the fuel system. Keep an ABC type fire extinguisher nearby.*

Review each of the codes that apply to LPG generator set installation. Paragraph 2-11 (LP-Gas Engine Fuel installations) of NFPA Pamphlet 501C and paragraph 3-6.2.5 of NFPA 58 (piping hose and fittings). These sections deal with fuel tanks and lines, but does not cover all applicable codes and regulations. Obtain this pamphlet by writing to the address listed in the beginning of this manual.

Mount a manual shutoff valve on the fuel supply tank. When installing the fuel lines, keep these factors in mind:

- Install LPG fuel lines to be accessible, but protected from damage.
- Use metal straps without sharp edges to secure fuel lines.
- Keep fuel lines away from hot engine or exhaust.
- Do not run fuel lines next to electrical wiring.

---

Do not connect the genset fuel supply line to any appliance fuel supply line. The genset can draw fuel away from other appliances and cause a flame out. To prevent the possibility of flameout, the fuel supply system must be designed to deliver sufficient fuel for normal operation of the genset and other appliances at the expected temperature conditions. It may be necessary to use a separate fuel tank for the genset if sufficient fuel cannot be supplied with a single tank system.

**⚠WARNING** *LPG fuel presents the hazard of explosion or fire which can result in severe personal injury or death. If flameout occurs with an unvented appliance, LP gas can accumulate inside the vehicle and create a safety hazard. Do not connect the generator set fuel supply line to an LP gas supply line that is supplying another appliance.*

### **Testing Fuel System for Leaks**

Before operating the set, test the LPG fuel system for leaks. Testing must conform to procedures listed in NFPA-58, or to the UL recommended test procedure, as follows:

After assembly and before initial operation, all fuel system connections, hose, valves, regulators, and fittings must be tested and proven free of leaks using a soap-and-water (or equivalent) solution while the system is under gas or air pressure of at least 90 psi (620 kPa).

Other approved methods of detecting leaks may be used if appropriate. This test shall NOT be made with a flame.

**⚠WARNING** *LPG fuel presents the hazard of explosion or fire which can result in severe personal injury or death. Do not smoke or allow any flame, spark, pilot light, arc-producing equipment or other ignition sources around fuel or fuel components.*

# 8. Electrical Connections

---

## GENERAL

This section covers installing the generator set electrical system for:

- Connecting the load
- Connecting a remote control
- Connecting the battery

Connect the battery last, to avoid accidentally starting or short-circuiting the set during installation.

**⚠WARNING** *Accidentally starting the generator set during installation can cause severe personal injury or death. Do not connect the starting battery until instructed to do so in the Initial Start and Checks section.*

The wiring must meet all applicable electrical codes. For this reason, a qualified electrician should install and inspect the wiring.

Mount switches and controls securely, to prevent damage from vibration and road shocks. All switches must be vibration-proof to prevent accidental opening or closing while the vehicle is in motion.

## AC WIRING

### Wire Types

The leads attached to the generator set output must have a current rating not less than 115 percent of the nameplate current rating of the generator set. The Onan-supplied AC feeder conductor insulation is rated at 125°C. Wires connected to the Onan feeder conductors must

either meet this insulation rating, or be a larger size (see National Electrical Code, NFPA 70).

Use stranded wire for all load connections. Load wiring must be appropriately sized and insulated for the specified current rating. Grounding must comply with all codes.

### Conduit

Install the generator load conductors in a flexible conduit. Cut the conduit to length, leaving extra wire for the junction box connections. Connecting wires must be correctly sized and insulated for the current rating. Round off or cover the ends of the conduit, to prevent its sharp edges from cutting the insulation.

Use waterproof conduit if the conduit is run outside of a compartment.

To reposition the 90° conduit fitting, loosen the locking nut (toothed ring), turn fitting counterclockwise to desired location, and retighten locking nut.

Seal all openings made for conduit into the vehicle interior, so exhaust or fuel vapor cannot enter the living quarters. Flexible metal conduit must be sealed internally at the end where it terminates inside the junction box or panel board (flexible conduit is not vapor-tight along its length).

**⚠WARNING** *Exhaust gas and fuel fumes present the hazard of severe personal injury or death. To prevent exhaust gas and fuel fumes from entering the vehicle interior, seal all openings made for conduit, wiring, etc. Also seal the wiring within the conduit itself. Use a silicone/rubber based sealant.*

---

## Wiring Disconnect Method

There must be no chance that an outside power source be connected to the generator set. Feeder conductors from the set compartment must terminate in a 120-volt double-pole, double-throw, positive-off switching device mounted ahead of the vehicle distribution panel; or they must connect to a generator set receptacle box. Figures 8-1 and 8-2 show examples of the wire connection.

## Line Circuit Breaker

The generator set has a line circuit breaker mounted on the front of the set mounted control panel. The breaker provides short circuit and overload protection for the generator.

## Load Connections

The generator output voltage and maximum current rating are specified on the generator nameplate.

Load wiring must be appropriately sized and insulated for the specified current rating. Grounding procedure must comply with codes.

A lead to be connected to an output feeder conductor shall not be more than two AWG sizes smaller than the output lead conductor and the insulation shall be:

- Rubber (with braid), neoprene, or thermoplastic, with a wall thickness of at least 0.030 inch (0.76 mm).

- Other material having the same or better electrical and mechanical properties.

**⚠WARNING** *Electrical shock can cause severe personal injury or death. Use only approved power supply assemblies. Never remove the grounding pin from assemblies. Incorrect ground or no ground can cause the vehicle to become electrically "hot". Equip the vehicle with adequate Ground-Fault Circuit Protection devices to meet the National Electrical Code (NFPA 70, 551-9[C]) and for personal safety.*

**⚠WARNING** *Gasoline fuel can be accidentally ignited by electrical sparks, presenting the hazard of fire or explosion, which can result in severe personal injury or death. For this reason, when installing the generator set:*

- *Do not tie electrical wiring to fuel lines.*
- *Do not run electrical lines and fuel lines through the same compartment openings unless they are physically separated by running them through individual channels, or by passing each line through a separate piece of tubing.*
- *Keep electrical and fuel lines as far apart as possible.*
- *Place a physical barrier between fuel lines and electrical lines wherever possible.*

**\*IMPORTANT!**

GROUND-FAULT CIRCUIT INTERRUPTERS (GFCIs) ARE REQUIRED BY THE NATIONAL ELECTRICAL CODE (NFPA 70, 551-9 [C]) IN ALL EXTERNAL AND SOME INTERNAL OUTLETS. TO PROPERLY EQUIP YOUR RECREATIONAL VEHICLE WITH THESE PROTECTION DEVICES, CONTACT YOUR RV MANUFACTURER OR DEALER FOR RECOMMENDATIONS.

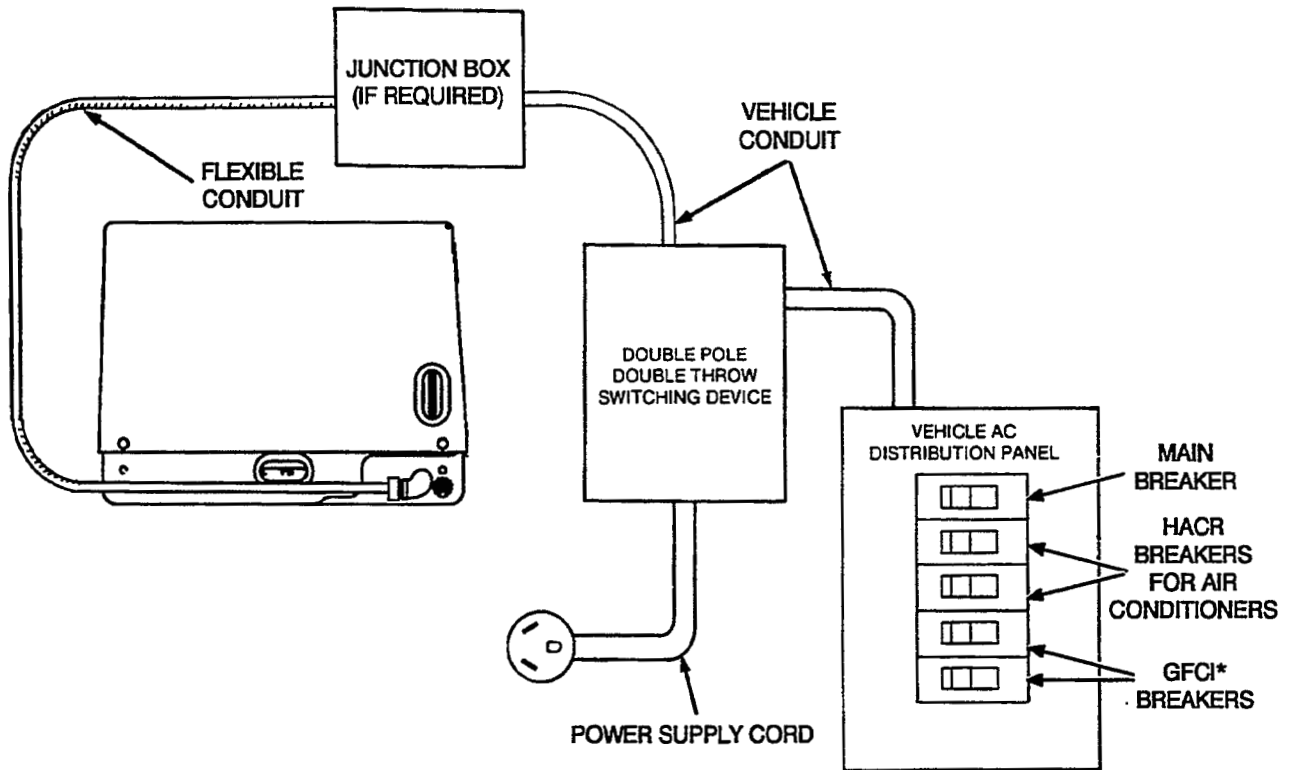

SC1463-7a

**FIGURE 8-1. SWITCHING DEVICE WIRING FOR UTILITY POWER**

**\*IMPORTANT!**

GROUND-FAULT CIRCUIT INTERRUPTERS (GFCIs) ARE REQUIRED BY THE NATIONAL ELECTRICAL CODE (NFPA 70, 551-9 [C]) IN ALL EXTERNAL AND SOME INTERNAL OUTLETS. TO PROPERLY EQUIP YOUR RECREATIONAL VEHICLE WITH THESE PROTECTION DEVICES, CONTACT YOUR RV MANUFACTURER OR DEALER FOR RECOMMENDATIONS.

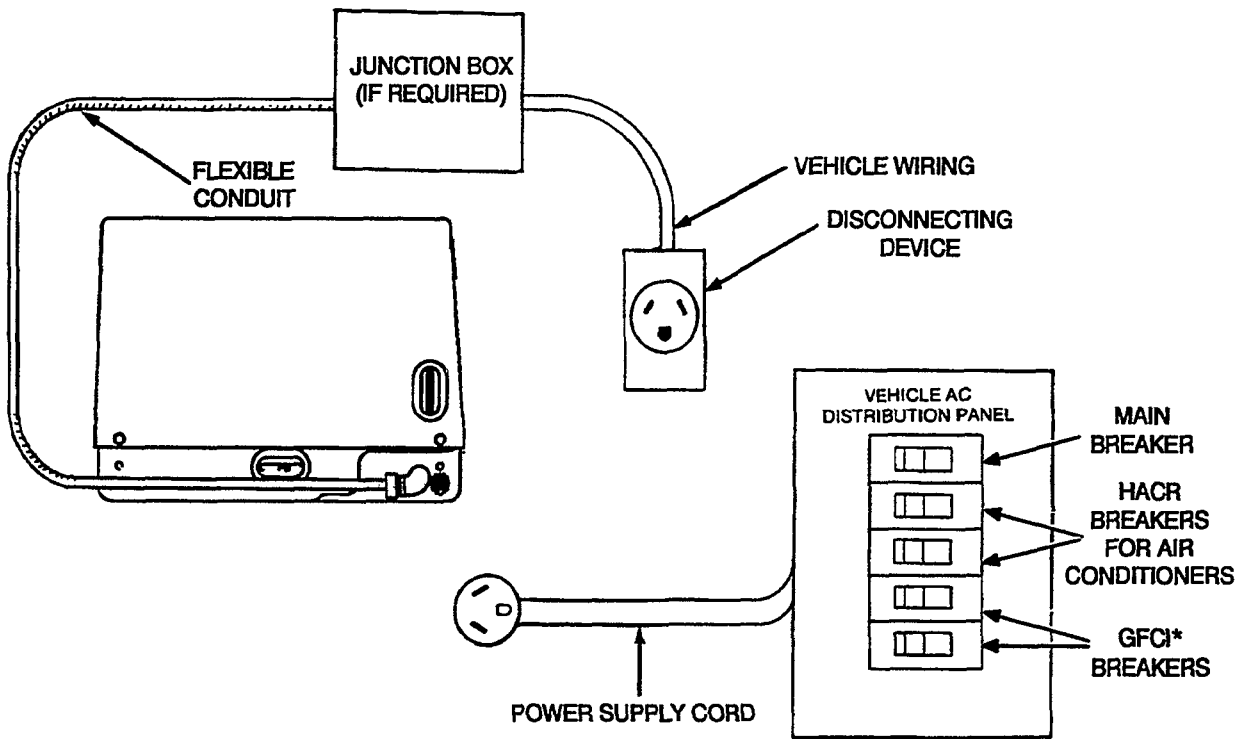

8C1464-4s

**FIGURE 8-2. UTILITY POWER CORD FOR SWITCHING**

## DC WIRING

### Remote Control (Option)

Onan offers optional remote control kits that can be connected to the generator set (Figure 8-4). The Standard Remote Control includes a start/stop switch and an indicator lamp. The Deluxe Remote Control has these items plus a running time meter and a battery condition meter.

The remote control connector plug is located inside the housing (Figure 8-3). Contact an Onan dealer for the proper remote control connector plug and wiring harness lead assembly.

**CAUTION** Use of a remote control switch other than the optional Onan remote controls can result in generator set starting battery discharge in the stop condition. The remote control Start/Stop switch must be a momentary-type switch in the Start and Stop positions.

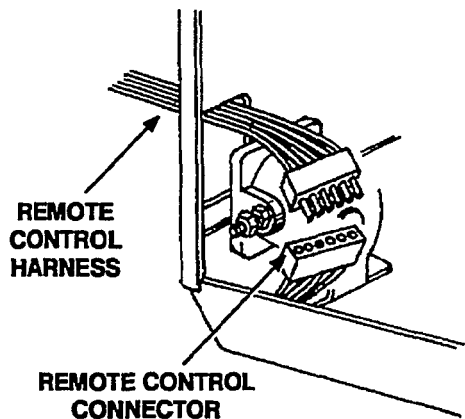

ES1994

FIGURE 8-3. REMOTE CONTROL CONNECTION

Location of the remote control can vary by application. Refer to the instructions supplied with the remote control kit for more installation information and important safety precautions.

Be sure to seal all openings made for wiring so exhaust or fuel vapors cannot enter the living quarters. If flexible metal conduit is used it must be sealed internally at the end where it terminates. Flexible metal conduit is not vapor-tight along its length due to its construction.

**WARNING** Inhalation of exhaust gas or ignition of fuel vapor can cause severe personal injury or death. Be sure to vapor-seal flexible metal conduit and all openings made during installation of the generator set with a silicone/rubber based sealant.

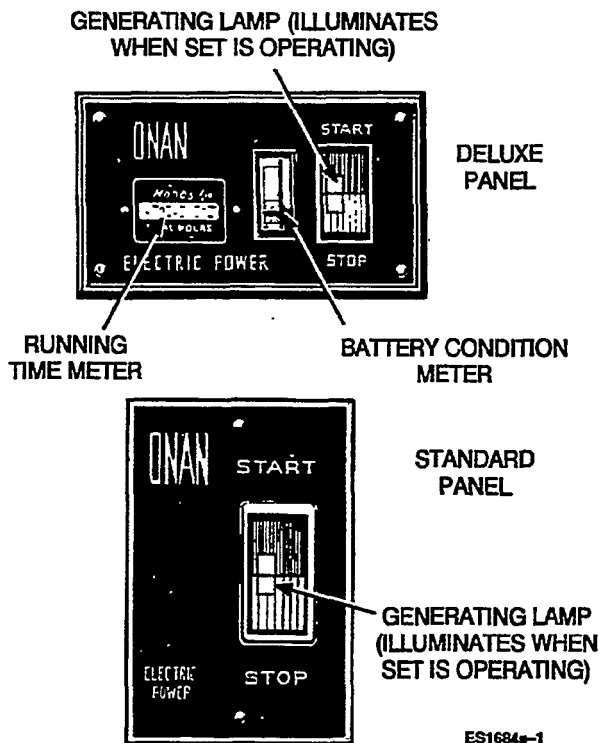

ES1684a-1

FIGURE 8-4. REMOTE CONTROL PANELS

## Starting Battery and Cable Selections

The generator set requires a 12-volt battery with a rating of 360 cold-cranking amps. A larger capacity battery will be required if it powers other coach accessories. Onan does not recommend that the vehicle starting battery be used to operate the generator set. Doing this can discharge the battery under some operating conditions.

For reliable cold-weather starting, the voltage drop from the battery terminals to the generator set starter should not exceed 0.12 volts per 100 amperes of current while the generator set is cranking. Refer to Table 8-1 to determine cable size and Table 8-2 for battery rating.

**TABLE 8-1. CABLES FOR COLD WEATHER STARTING TO -20°F (-29°C)**

*CABLE LENGTH IN FEET (METRES)	CABLE SIZE
0-10 (0-3)	2**
11-15 (3-4.5)	0
16-20 (4.5-6)	000

\* Distance from battery to set.

\*\* For warm weather operation, #2 cable can be acceptable up to 20 feet (6.1 m).

**TABLE 8-2. COLD CRANKING AMPS FOR MINIMUM 12-VOLT BATTERY\***

ABOVE 32° F (0° C)	BELOW 32° F (0° C)
360 Cold Cranking Amps (Approx. 70 amp/hour)	450 Cold Cranking Amps (Approx. 95 amp/hour)

\* Larger capacity batteries will be required if battery is also used to power other coach accessories.

### Battery Compartment

Mount the battery in its own compartment, away from the generator set and any spark-producing device. For ventilation, provide the battery compartment with an opening of at least 1.7 in<sup>2</sup> (11 cm<sup>2</sup>) at the top and 1.7 in<sup>2</sup> (11 cm<sup>2</sup>) at the bottom.

Mount the battery on a rigid support structure, where leaks and accidental spills cannot damage the generator set, fuel lines, and wiring.

**⚠WARNING** Batteries present the hazard of explosion, which can result in severe personal injury. Because batteries give off explosive gas, install the battery in a separate compartment from the generator set and away from all flames, pilot light, arcing, or spark-producing devices.



## Battery Connections

Make sure that the frame (ground) connection (major frame member if possible) is secure enough to minimize electrical resistance. Avoid making this connection at a weld or mechanical joint. On short cable runs, the negative (-) battery cable can be connected between the generator set and the battery as long as the battery negative (-) has a separate 8 AWG chassis ground connection.

**⚠ WARNING** *Failure to ground the genset properly can result in injury or death. If the genset is not grounded to the vehicle chassis through the battery negative (-) cable, attach an 8 AWG equipment ground wire between the vehicle chassis and the battery negative (-) connection.*

Route the battery cables between the genset and its starting battery. Make sure that the cables are long enough, but do not connect them to the battery until instructed to do so in the *Initial Start and Checks* section of this manual. Provide adequate support for the battery cables to avoid abrasion wear due to vibrations, when the vehicle is in transit.

**Positive (+) Battery Cable:** Connect this cable to the start relay B+ post with a 3/8-inch ring terminal. Tighten the B+ connection securely (Figure 8-5).

**⚠ CAUTION** *Failure to secure the B+ terminal can result in personal injury and/or equipment damage from an electrical short. See that the terminal connection is secure. If necessary secure lead to prevent abrasion.*

**Negative (-) Battery Cable:** Connect this cable securely to the genset base battery negative (-) connection with a 3/8-inch ring terminal (Figure 8-5). Use the same size cable for both positive and negative battery connections. Make sure that the battery negative (-) circuit is tied to chassis ground at the starting battery negative (-) terminal or at the battery negative (-) connection on the genset base. Check to confirm that good electrical ground connection is made (Figure 8-5).

**⚠ WARNING** *Batteries present the hazard of explosion, which can result in severe personal injury. Because batteries give off explosive gas, always disconnect the negative (-) cable first, and connect it last to reduce the risk of arcing.*

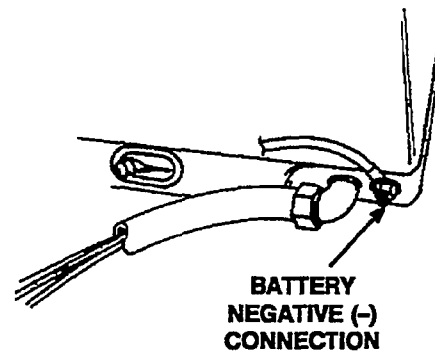
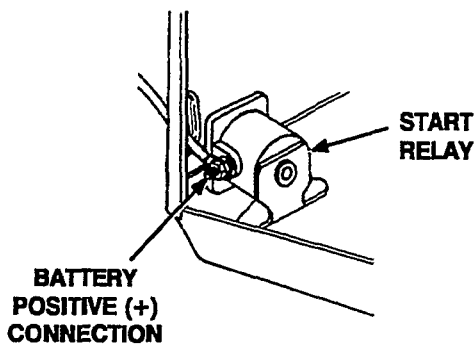

ES1993-2

ES1992

FIGURE 8-5. BATTERY CONNECTIONS



# 9. Initial Start and Checks

## **⚠ WARNING**

### **EXHAUST GAS IS DEADLY!**

**Exhaust gases contain carbon monoxide, an odorless and colorless gas. Carbon monoxide is poisonous and can cause unconsciousness and death. Symptoms of carbon monoxide poisoning can include:**

- **Dizziness**
- **Nausea**
- **Headache**
- **Weakness and Sleepiness**
- **Throbbing in Temples**
- **Muscular Twitching**
- **Vomiting**
- **Inability to Think Coherently**

**IF YOU OR ANYONE ELSE EXPERIENCE ANY OF THESE SYMPTOMS, GET OUT INTO THE FRESH AIR IMMEDIATELY. If symptoms persist, seek medical attention. Shut down the unit and do not operate until it has been inspected and repaired.**

**Never sleep in vehicle with the generator set running unless the vehicle interior is equipped with an operating carbon monoxide detector. Protection against carbon monoxide inhalation also includes proper exhaust system installation and visual and audible inspection of the complete exhaust system at the start of each generator set operation.**

1-RV

## **PRE-START CHECKS**

Before starting the generator set, perform these steps:

1. Perform the Installation Review described in this section.
2. Check the engine oil level. Remove and clean the oil level indicator. Insert the oil level indicator into the oil filler neck. It is not necessary to screw the oil level indicator in to obtain an oil level reading. If low, add oil very slowly until the Full mark is reached. Screw the oil level indicator into the filler neck securely to prevent oil leakage.

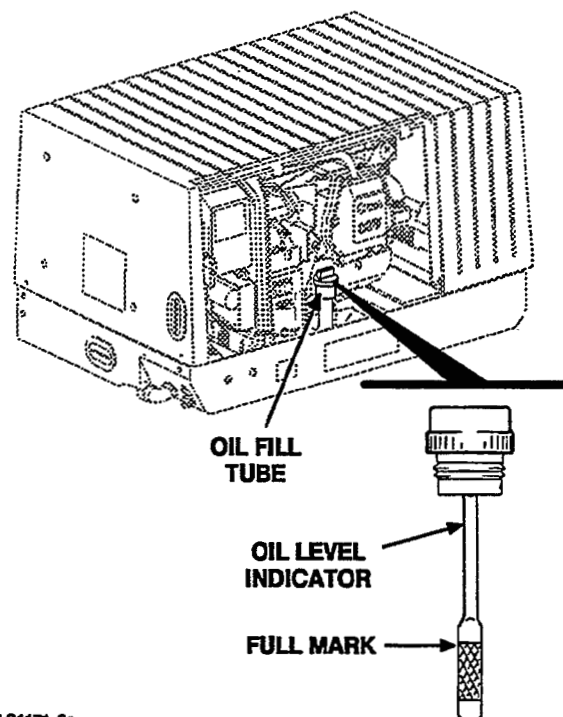

LS1171-2a

**FIGURE 9-1. OIL LEVEL INDICATOR**

3. Check that battery terminals and cable connectors are clean and dry. Connect the positive (+) battery cable to the POS. (+) battery post first, then connect the negative (-) battery cable to chassis ground or the NEG. (-) battery post if the battery has a separate vehicle chassis ground cable. Always connect the negative (-) battery cable last to reduce the risk of arcing.

**⚠WARNING** Batteries present the hazard of explosion, which can result in severe personal injury. Because batteries produce explosive gas, do not smoke or allow any arc-producing devices in the battery area. Do not disconnect cables from the battery while the generator set is cranking or running. This causes arcing and can result in an explosion.

4. Review the Operator's Manual, and note the features of the genset. Open the fuel supply valve to the generator set (if equipped).

## INITIAL STARTING AND CHECKS

**⚠WARNING** Exhaust gas presents the hazard of severe personal injury or death. Do not operate the generator set inside any room or building.

### Starting from the Set Mounted Control

1. Move the Start/Stop switch to the START position (Figure 9-2). The engine should crank and start. The set may need more cranking during the initial start, to prime the fuel system. If the genset fails to start, see the *Troubleshooting Guide* in the Operator's Manual.

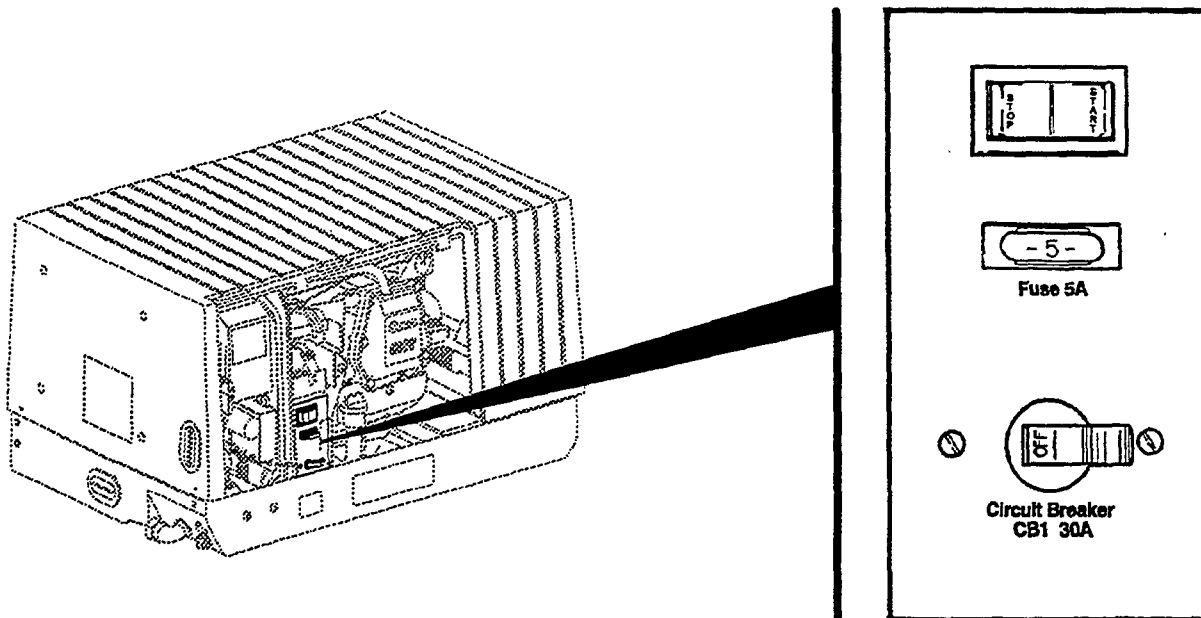

M1899

FIGURE 9-2. STANDARD CONTROL PANEL

- 
2. After the set starts, check for fuel leaks. If any leaks are found, stop the set immediately, close the fuel supply valve (if equipped) and have the leak(s) repaired. Make sure that the fuel lines do not touch anything that can damage them. Do not operate the set for more than a few minutes with the access cover removed or the generator set will overheat.

**⚠WARNING** *Fuel presents the hazard of explosion or fire that can result in severe personal injury or death. If a fuel leak is found, stop the generator set and have the leak repaired immediately.*

**⚠WARNING** *A hot generator set can cause severe burns. Always allow the generator set to cool down before performing service.*

3. Examine the exhaust system for leaks. If any leaks are found, stop the set and have the exhaust system repaired immediately.

**⚠WARNING** *Exhaust gas presents the hazard of severe personal injury or death. Inspect the exhaust system audibly and visually. With the generator set running, and the service access cover removed, inspect the muffler. Do not operate the generator set if it is excessively noisy. Have any leaks repaired immediately.*

4. Operate the set with a normal load, monitoring fuel supply connections, exhaust system, set performance, and amount of noise reduction. If set performance is not acceptable, see the Service Manual for adjustment procedures, or contact an authorized Onan service center for assistance. If the generator set requires adjustment or repair, disconnect the starting battery, negative (–) cable first, to prevent accidental start-up.

**⚠WARNING** *Accidental starting of the generator set during maintenance procedures can cause severe personal injury or death. Disconnect the generator set starting battery, negative (–) cable first, before performing maintenance.*

5. Move the Start/Stop switch to the STOP position to stop the generator set.

#### **Starting from the Remote Control**

1. Move the Remote Start/Stop switch to the START position. The engine should crank and start as indicated by indicator light on the switch. If it does not, see the *Troubleshooting Guide* in the Operator's Manual. Check all remote control connections, repair if necessary, and restart the set.
2. After the genset starts, check the battery condition meter (if equipped) to confirm its proper operation.
3. Move the Start/Stop switch to the STOP position to stop the generator set.

---

## INSTALLATION REVIEW

Prior to initial start-up of the generator set, check (✓) each of the following items. For a proper installation, each answer must be yes: if not, that aspect of the installation should be reworked or provision made to satisfy the requirement.

- If installed in a compartment, Is the compartment metal-lined and sealed around all edges?
- Are wiring holes into the inside of coach (including the inside of AC conduit) sealed to prevent passage of exhaust gases?
- Can the following routine maintenance items be performed through the vehicle access panel? Refer to Figure 3-3.
  - Change oil
  - Adjust carburetor
  - Start/Stop the unit
  - Change air filter
  - Adjust governor
  - Access AC circuit breaker and control fuse
  - Change spark plug
- Are air inlet and exhaust openings clear and large enough (see *Mounting* section) for proper airflow?
- If the installation is for an under-floor kit, is there a metal barrier between the genset and a combustible floor? See Figure 3-8.
- Are fuel lines and electrical wires protected from chafing and damage and are they insulated from each other? Refer to Figure 3-11.
- Are all fuel connections and hose clamps tight? Refer to Figure 3-12.
- Is a flexible section of non-conducting fuel line installed between the fuel inlet and the fuel line from the tank? Refer to Figure 3-12.
- Are all electrical leads connected and protected, and is the conduit adequately supported? Refer to Figure 3-13, -14, -15, and -16.
- Does the exhaust system extend beyond the perimeter of the vehicle a minimum of 1 inch (25 mm)? See Figure 3-18.
- Are there operable windows, doors or storage compartments within a triangle formed by a base one foot on either side of the exhaust pipe and 3 feet above the exhaust pipe? Refer to Figure 3-21.
- If the exhaust system is run into the angle of approach or departure (see Figure 3-20), is it protected from bottoming out by use of skid bars, rollers, etc.?
- Is the exhaust system secure and are all connections tight? Are all required exhaust clamps, hangers, and support straps in place per the *Exhaust System* section of this manual and the kit instructions?
- Is the generator set protected from direct road splash from vehicle wheels?

# 10. Wiring Schematic\Diagram

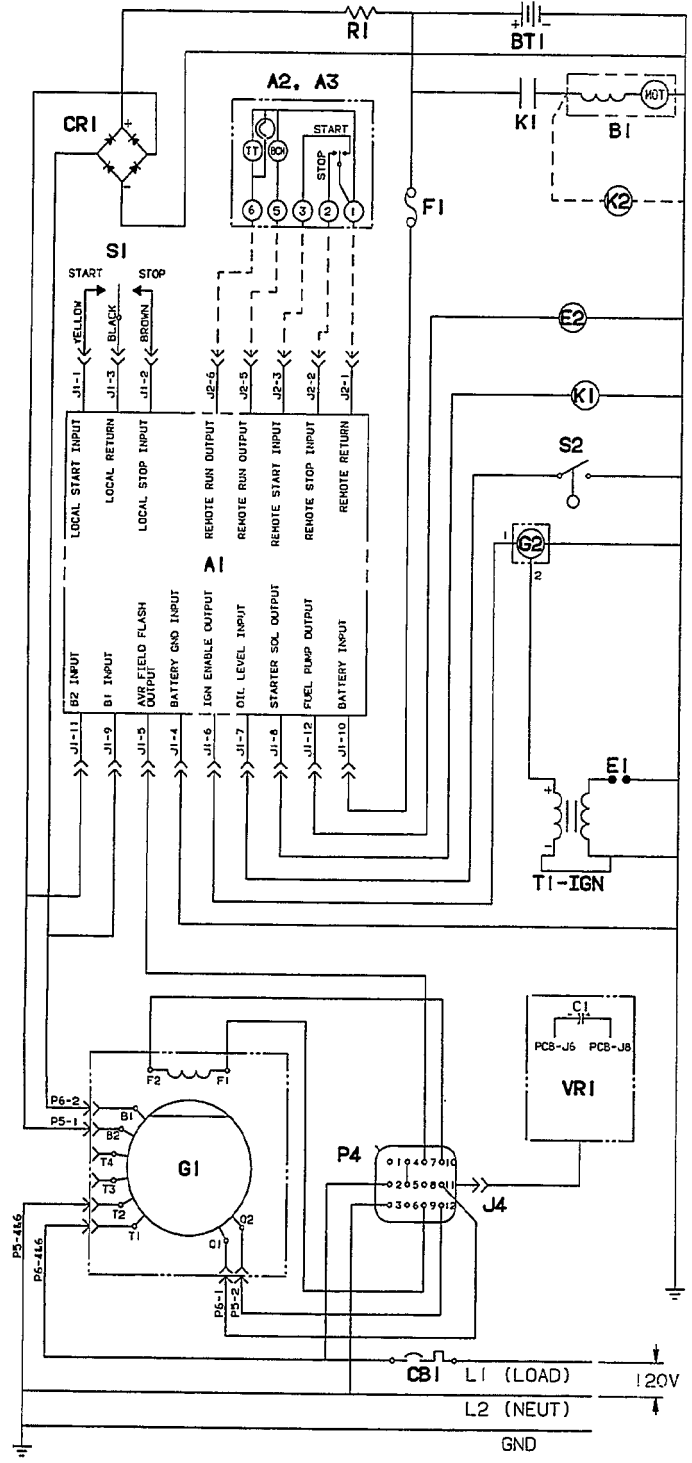

Item	Description
VR1	REGULATOR-VOLTAGE
T1-IGN	COIL-IGNITION
S2	SWITCH-LOW OIL LEVEL
S1	SWITCH-START-STOP
R1	RESISTOR-BATTERY CHARGE
K2	SOL-REGULATOR LP
K1	RELAY-STARTER
G2	MAGNETO-IGNITION
G1	GENERATOR
F1	FUSE
E2	FUEL PUMP/FUEL SHUTOFF SOLENOID (LP)
E1	SPARK PLUG
CR1	RECTIFIER-BRIDGE
CB1	CIRCUIT BREAKER (AC OUTPUT)
BT1	BATTERY 12V
B1	MOTOR-STARTER
A3	REMOTE CONTROL-STANDARD
A2	REMOTE CONTROL-DELUXE
A1	CONTROL ASSY

FIGURE 10-1. WIRING SCHEMATIC 611-1194

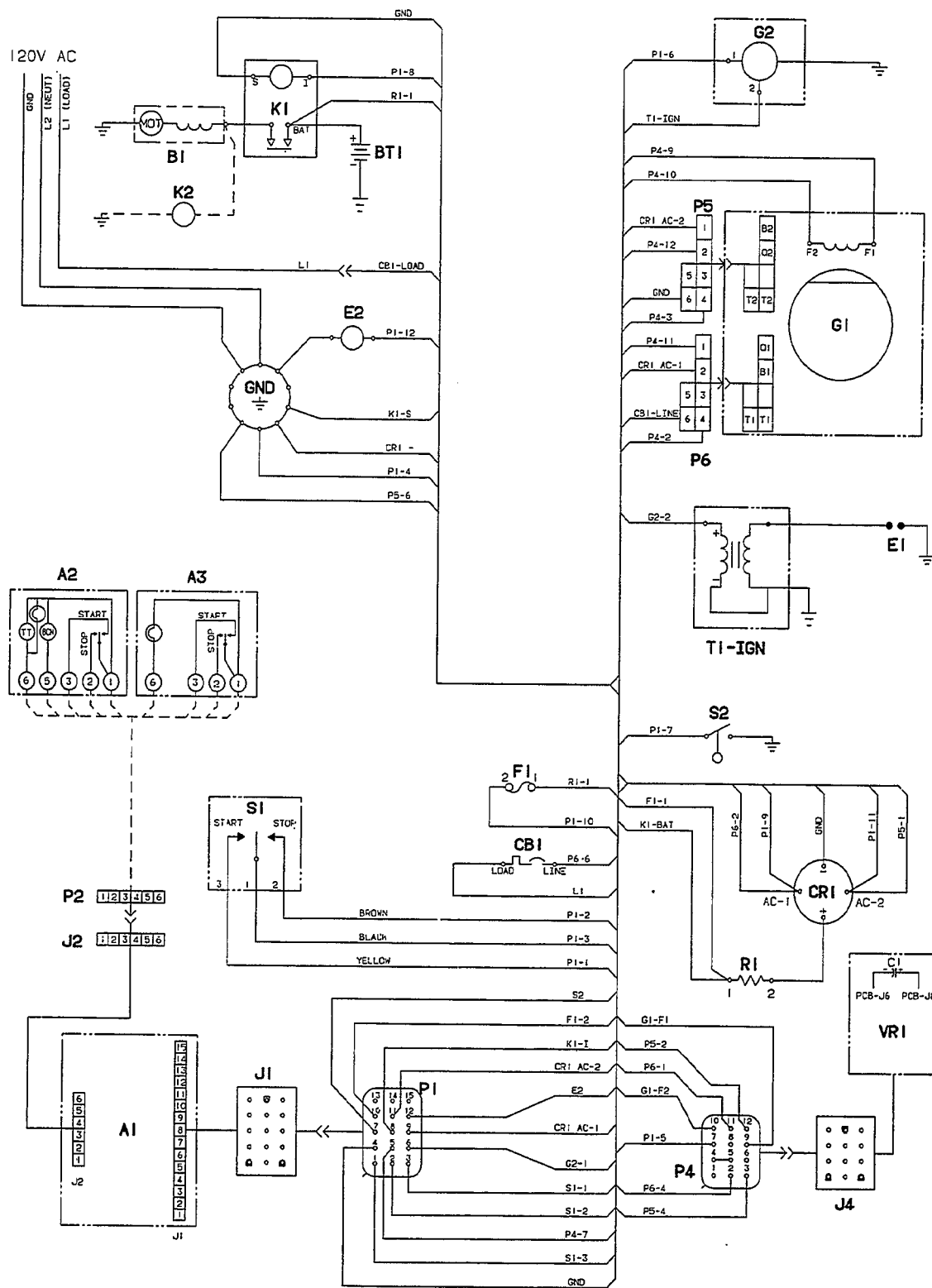
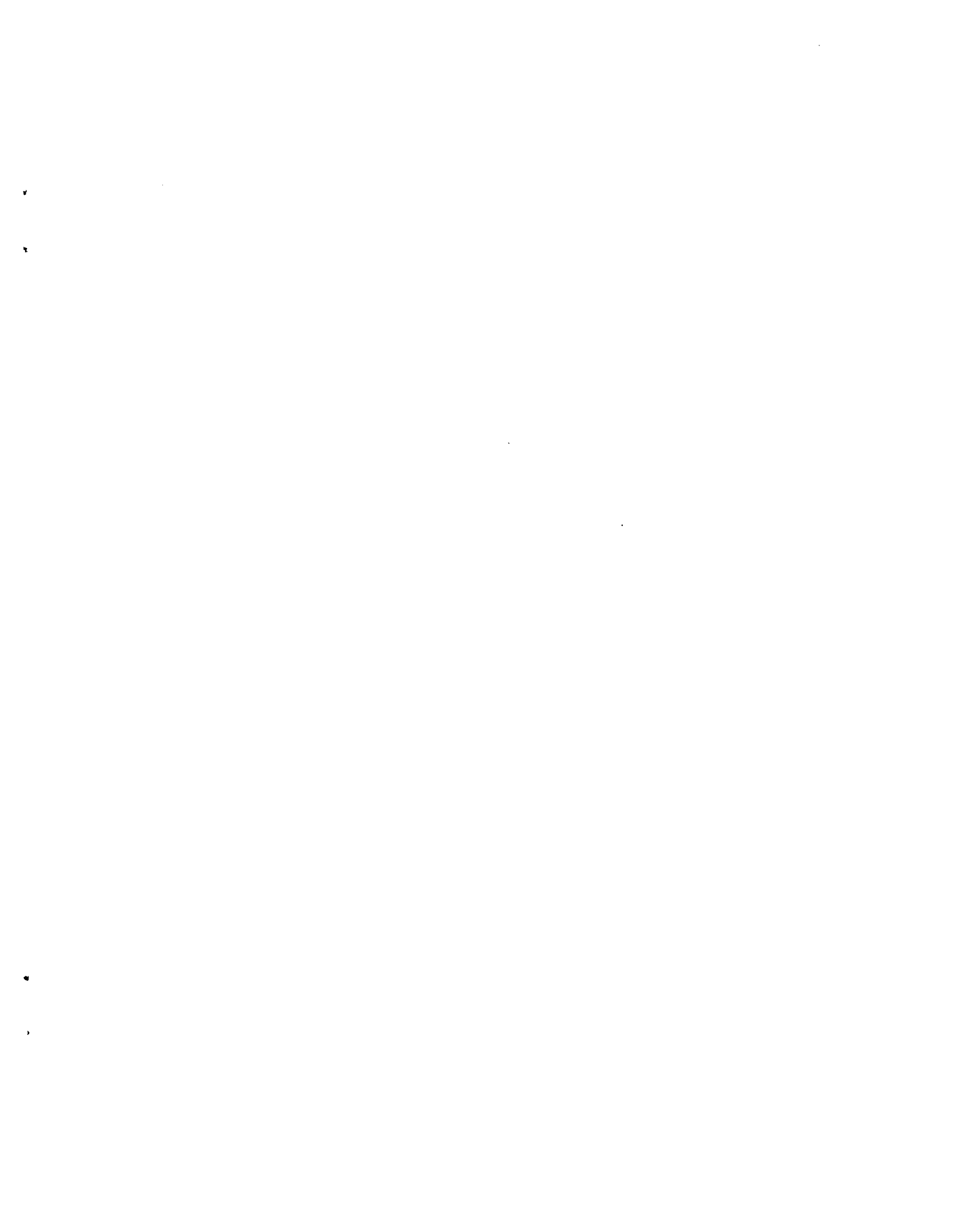

FIGURE 10-2. WIRING DIAGRAM 611-1194







Cummins Power Generation  
1400 73rd Avenue N.E.  
Minneapolis, MN 55432  
763-574-5000  
Fax: 763-574-8087

Cummins and Onan are registered trademarks of Cummins Inc.